

Directory

01

Insert

P1-P38

Turnline ISO Insert
Turnline Ceramic Insert
Turnline CBN Insert
Turnline PCD Insert

02

External Toolholder

P39-P50

Multi-clamp Toolholder
Screw-on Clamp Toolholder

03

Internal Toolholder

P51-P65

Multi-clamp Toolholder
Screw-on Clamp Toolholder
Steel Boring Bar with Coolant Hole

04

Threading

P66-P79

Thread Inserts
Thread Toolholder
Thread Inserts for Oil Pipe
Thread Toolholder for Oil Pipe

05

Parting, Grooving and Groove-Turn system

P80-P95

Turnline TKD Series
Turnline GB Series
Turnline TGE Series
Turnline TTF Series
Turnline TTS Series

06

Miniature Tool

P96-P109

Solid Boring Bar
Modular Small Hole Cutter

TurnLine Insert Code System (ISO)

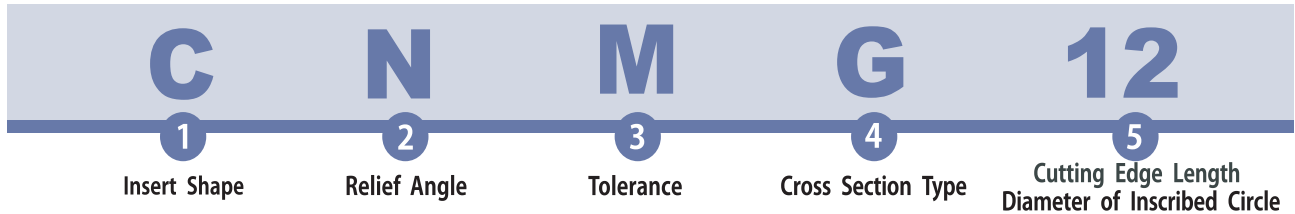

1 Insert Shape

C N M G 12 04 08 - MP

2 Relief Angle

C N M G 12 04 08 - MP

3 Tolerance

C N M G 12 04 08 - MP

d : Inscribed circle
t : Thickness
m : Refer to figure

Class	d	m	t
A	± 0.025	± 0.005	± 0.025
C	± 0.025	± 0.013	± 0.025
H	± 0.013	± 0.013	± 0.025
E	± 0.025	± 0.025	± 0.025
G	± 0.025	± 0.025	± 0.13
J *	± 0.05 ~ ± 0.15	± 0.005	± 0.025
K *	± 0.05 ~ ± 0.15	± 0.013	± 0.025
L *	± 0.05 ~ ± 0.15	± 0.025	± 0.025
M *	± 0.05 ~ ± 0.15	± 0.08 ~ ± 0.20	± 0.13
N *	± 0.05 ~ ± 0.15	± 0.08 ~ ± 0.18	± 0.025
U *	± 0.08 ~ ± 0.25	± 0.13 ~ ± 0.38	± 0.13

4 Cross Section Type

C N M G 12 04 08 - MP

* Sides are based on unground insert

Tolerance on C, E, H, M, O, P, R, S, T, W Insert Shape (Exceptional case)

d	Tolerance on d		Tolerance on m	
	J, K, L, M, N	U	M, N	U
6.35	± 0.05	± 0.08	± 0.08	± 0.13
9.525	± 0.05	± 0.08	± 0.08	± 0.13
12.7	± 0.08	± 0.13	± 0.13	± 0.20
15.875	± 0.10	± 0.18	± 0.15	± 0.27
19.05	± 0.10	± 0.18	± 0.15	± 0.27
25.4	± 0.13	± 0.25	± 0.18	± 0.38

Tolerance on D Insert Shape (Exceptional case)

d	Tolerance on d	Tolerance on m
6.35	± 0.05	± 0.11
9.525	± 0.05	± 0.11
12.7	± 0.08	± 0.15
15.875	± 0.10	± 0.18
19.05	± 0.10	± 0.18

04 08 - MP

6 7 8

Thickness of Cutting Edge

Nose Radius (Nose R)

Chipbreaker for Turning

5 Cutting Edge Length, Diameter of Incribed Circle
C N M G 12 04 08 - MP

Symbol								Inch	IC d (mm)
C	d	S	T	R	V	W			
03	04	03	06	03	-	02	1.2(5)	3.97	
04	05	04	08	04	08	S3	1.5(6)	4.76	
05	06	05	09	05	09	03	1.8(7)	5.56	
-	-	-	-	06	-	-	-	6.00	
06	07	06	11	06	11	04	2	6.35	
08	09	07	13	07	13	05	2.5	7.94	
-	-	-	-	08	-	-	-	8.00	
09	11	09	16	09	16	06	3	9.525	
-	-	-	-	10	-	-	-	10.00	
11	13	11	19	11	19	07	3.5	11.11	
-	-	-	-	12	-	-	-	12.00	
12	15	12	22	12	22	08	4	12.70	
14	17	14	24	14	24	09	4.5	14.29	
16	19	15	27	15	27	10	5	15.875	
-	-	-	-	16	-	-	-	16.00	
17	21	17	30	17	30	11	5.5	17.46	
19	23	19	33	19	33	13	6	19.05	
-	-	-	-	20	-	-	-	20.00	
22	27	22	38	22	38	15	7	22.225	
-	-	-	-	25	-	-	-	25.00	
25	31	25	44	25	44	17	8	25.40	
32	38	31	54	31	54	21	10	31.75	
-	-	-	-	32	-	-	-	32.00	

() Symbol for small size insert

7 Nose Radius (Nose R)
C N M G 12 04 08 - MP



Symbol		Corner Radius	
Metric	Inch	Metric	Inch
01	0	0.1	0.004
02	0.5	0.2	0.008
04	1	0.4	1/64
08	2	0.8	1/32
12	3	1.2	3/64
16	4	1.6	1/16
20	5	2.0	5/64
24	6	2.4	3/32
28	7	2.8	7/64
32	8	3.2	1/8
00	-	Round insert (Inch)	
M0	-	Round insert (Metric)	

6 Thickness of Cutting Edge
C N M G 12 04 08 - MP

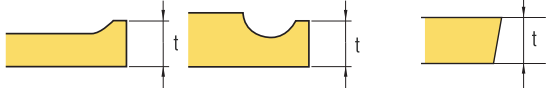

Symbol		Thickness of Cutting Edge (t)	
Metric	Inch	mm	Inch
01	1(2)	1.59	1/16
T0	1.125	1.79	9/128
T1	1.2	1.98	5/64
02	1.5(3)	2.38	3/32
T2	1.75	2.78	7/64
03	2	3.18	1/8
T3	2.5	3.97	5/32
04	3	4.76	3/16
05	3.5	5.56	7/32
06	4	6.35	1/4
07	5	7.94	5/16
09	6	9.52	3/8
11	7	11.11	7/16
12	8	12.70	1/2

() Symbol for small size insert

8 Chipbreaker for Turning
C N M G 12 04 08 - MP



PF PM GM MP MK No Chipbreaker

FM SF US UG PU TQ

LR 25UL 15D 15M 24UL PS

MM KS UA UT 13U 15V

15U 12U 16X 15K 14VI AL

Standard Cutting Conditions
Coated Grade

Work Materials	Work Condition	Grade	Cutting Speed (m/min)	ISO	Cutting Performance
P Steel	Continuous	TP710	150-360	P01	
		TP7110	150-360	P10	
		TC580	100-250	P20	
		TC230	100-250	P30	
		GT301	100-250	P40	
		GT601	100-250	P50	
	Interrupted	TP720	120-280		
		TP7220	120-280		
M Stainless Steel	Continuous	TM810	100-220	M01	
		TM8110	100-220	M10	
		TJ15	50-180	M20	
		TJ20U	50-180	M30	
	Interrupted	TM820	100-220	M40	
		TM8220	100-220	M50	
K Cast Iron	Continuous	TK910	200-400	K01	
	Interrupted	TK920	150-300	K10	
				K20	
				K30	
N Non-ferrous Metal	Continuous	TN320	100-1000	N10	
				N20	
S Superalloys Titanium	Continuous	TMS3115	40-70	S01	
				S10	
	Interrupted	TMS3125	45-65	S20	
				S30	
H Hard Materials	Continuous	TH510	60-150	H10	
				H20	

Standard Cutting Conditions
Coated Grade

Work Materials	ISO	Coated Carbide			Cermets	Coated Cermets
		CVD	PVD	No Coated		
P Steel	P01				TC580	GT301
	P10	TP710			TC230	GT601
	P20	TP710 TP720		TJ15 TJ20U		
	P30	TP720 TP720				
	P40					
	P50					
M Stainless Steel	M01					
	M10					
	M20		TM810 TM8110 TJ15 TJ20U			
	M30		TM820 TM8220			
	M40					
	M50					
K Cast Iron	K01	TK910			TC580	GT301
	K10				TC230	GT601
	K20		TK920			
	K30					
N Non-ferrous Metal	N10					
	N20			TN320		
S Superalloys Titanium	S01					
	S10		TMS3115 TMS3125			
	S20					
	S30					
N Hard Materials	N10		TH510			
	N20					

TurnLine Chipbreaker Overview

Chipbreaker	Features	Application	Cutting Edge
PF	First choice chipbreaker for finishing steels. The dimple structure decreases the contact area between the insert surface and chips, resulting in significant reduction of heat occurrence.		
PM	General purpose chipbreaker used for medium cutting. Unique chipbreaker geometry with sharp edges and large rake angle assures free cutting action in a wide range of cutting conditions.		
MP	Excellent chip control when finish cutting. Outstanding chip control when high feed turning at small depth of cut.		
GM	Applicable to a wide range of cutting condition with sharp edge. Recommended chipbreaker for stainless steel turning.		
MK	Highly reliable chipbreaker for medium cutting under a wide range of conditions from continuous to interrupted cutting. Recommended chipbreaker for cast iron turning.		
No Chipbreaker	Can cover a wide range of applications from finishing to roughing of cast iron. Excellent in cutting edge strength.		
PS	3-dimensional chipbreaker designed to have excellent chip control capability and low cutting force in finishing to medium cutting. Low cost, M-class positive insert used for high efficiency in a wide range of applications.		

TurnLine Chipbreaker Overview

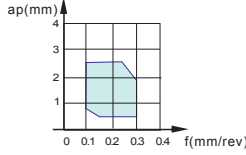
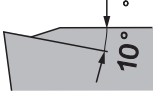
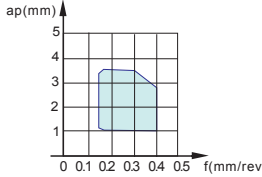
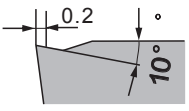
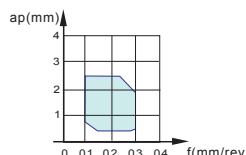
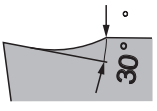
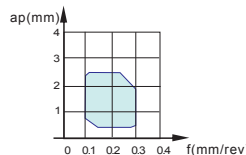
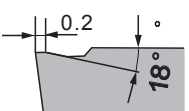
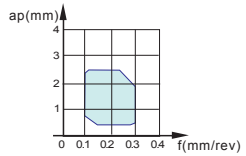
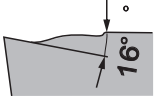
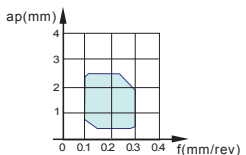
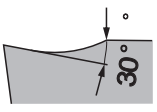
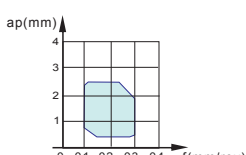
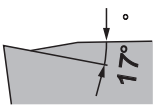
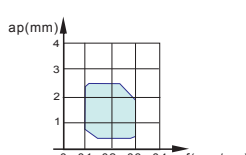
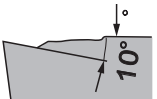
Chipbreaker	Features	Application	Cutting Edge
MM	Developed chipbreaker for medium cutting. Excellent chip control due to wide, positive chip flow zone.		
KS	Highly reliable chipbreaker for medium cutting under a wide range of conditions from continuous to interrupted cutting.		
25UL	High positive cutting edge reduces chip contact. Minimized temperature while machining ensures longer tool life. Stable machining with superior chip evacuation in high depth of cut.		
15D	Excellent chip control at wide range of cutting conditions. Suitable for stainless steel cutting.		
15M	Shallow depth of cut with sharp edge. Longer tool life at high speed cutting due to low cutting force. Good finishing surface.		
24UL	High positive cutting edge reduces chip contact. Minimized temperature while machining ensures longer tool life. Stable machining with superior chip evacuation in high depths of cut.		
15V	Longer tool life due to minimizing chip contact and reducing cutting heat while machining.		
12U/13U/15U	Improved chip control makes tool life longer and better machining.		

TurnLine Chipbreaker Overview

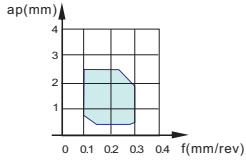
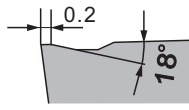
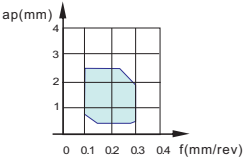
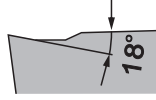
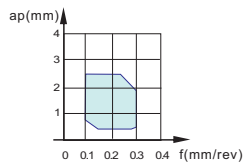
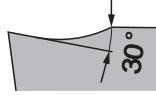
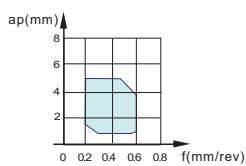
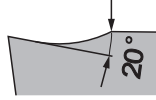
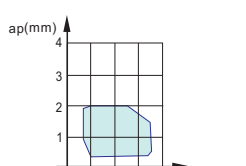
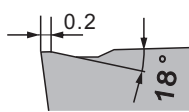
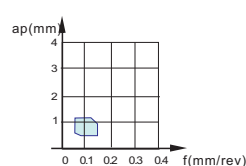
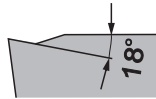
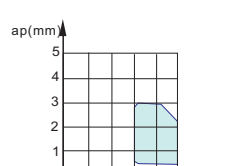
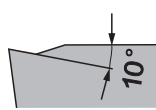
Chipbreaker	Features	Application	Cutting Edge
16X	Stable machinability in interrupted machining toughness. Stable chip evacuation and machining in machining with high depth of cut.		
15K	Excellent chip control in application with micro depth of cut and low feed. Low cutting load and super finishing surface. Excellent for both internal and external machining		
14VI	Longer tool life due to minimizing chip contact and reducing cutting heat while machining.		
AL	Extremely sharp cutting edge. Polished surface. Excellent chip forming at high cutting feeds. Low power consumption.		
FM	Suitable for finishing to medium cutting. Excellent chip control.		
SF	Large rake angle reduces cutting force. Less burring achieved by diminishing damage from notching.		
US	Superior cutting edge sharpness and strength achieved by a positive land. Extra strength of cutting edge inhibits damage from wall shouldering.		

TurnLine Chipbreaker Overview

Chipbreaker	Features	Application	Cutting Edge
UG	Large rake angle reduces cutting force. Less burring achieved by diminishing damage from notching.		
PU	General purpose chipbreaker. Excellent chip control at machining of low carbon steel.		
TQ	Sharp cutting performance with 3-D rake angle and double projection design.		
LR	Smooth chipbreaker geometry improves chip flow with less adhesion. Large curled chips.		
UA	Enables machining over a wide range of conditions by using the optimum chipbreaker width according to the cutting depth.		
UT	Strong edge chipbreaker for medium machining range.		

TurnLine Insert
Negative Type

● :Continuous Cutting ● :Light Interrupted Cutting

Application	Chipbreaker	Designation	Corner Radius	Coating														No Coated	Cermets	Coated Cermets						
				TP710	TP720	TP7110	TP7220	TM810	TM820	TM8110	TM8220	TK910	TK920	TMS3115	TMS3125	TH510	TJ15				TJ20U	TN320	TC580	TC230	GT601	GT301
Medium Cutting		TNMG160404-MP	0.4	●	●	●	●											●	●	●	●	●	●			
		TNMG160408-MP	0.8					●	●	●	●								●	●						
		TNMG160412-MP	1.2						●	●	●															
		TNMG220408-MP	0.8						●	●												●	●	●		
		TNMG220412-MP	1.2						●	●												●	●	●		
		TNMG220416-MP	1.6							●	●															
		TNMG160404-MK	0.4								●	●														
		TNMG160408-MK	0.8								●	●														
		TNMG160412-MK	1.2								●	●														
		TNMG160416-MK	1.6								●	●														
		TNMG220408-MK	0.8								●	●														
		TNMG220412-MK	1.2								●	●														
		TNMG220416-MK	1.6								●	●														
		TNMA110304	0.4								●	●														
		TNMA110308	0.8								●	●														
		TNMA160308	0.8								●	●														
		TNMA160404	0.4								●	●														
		TNMA160408	0.8								●	●														
		TNMA160412	1.2								●	●														
		TNMA160416	1.6								●	●														
TNMA220404		0.4								●	●															
TNMA220408		0.8								●	●															
TNMA220416		1.6								●	●															
		TNMG160404-US	0.4															○								
	TNMG160408-US	0.8															○									
	TNMG160404-UG	0.4															○									
	TNMG160408-UG	0.8															○									
	TNMG160404R/L-C	0.4																			●					
	TNMG160408R/L-C	0.8																			●					
	TNMG160404-PU	0.4																			●					
	TNMG160408-PU	0.8																			●					
	TNMG160404-TQ	0.4																			●					
	TNMG160408-TQ	0.8																			●					

● In Stock ○ Inquiry Each Time

External Toolholders:P42
Internal Toolholders:P52,P59

**TurnLine Insert
Negative Type**

● : Continuous Cutting ● : Light Interrupted Cutting

Application	Chipbreaker	Designation	Corner Radius	Coating													No Coated	Cermets	Coated Cermets							
				TP710	TP720	TP7110	TP7220	TM810	TM820	TM8110	TM8220	TK910	TK920	TMS3115	TMS3125	TH510				TJ15	TJ20U	TN320	TC580	TC230	GT601	GT301
Medium Cutting		TNGG160401R/L-25UL	0.1	●	●	●	●											●	●		●	●	●	●		
		TNGG160402R/L-25UL	0.2					●	●	●									●	●						
		TNGG160404R/L-25UL	0.4																			●	●	●	●	
		TNGG160402R/L-24UL	0.2																		●					
		TNGG160404R/L-24UL	0.4																		●					
		TNGG160401R/L-15D	0.1																			●				
		TNGG160402R/L-15D	0.2																			●				
		TNGG160404R/L-15D	0.4																			●				
		TNGG160408R/L-15D	0.8																			●				
		TNGG160402R/L-15M	0.2																			●				
		TNGG160404R/L-15M	0.4																			●				
		TNGG160408R/L-15M	0.8																			●				

● In Stock ○ Inquiry Each Time

External Toolholders: P42
Internal Toolholders: P52, P59

Insert
External Toolholder
Internal Toolholder
Threading
Parting, Grooving
Miniature Tool

● : Continuous Cutting ● : Light Interrupted Cutting





Application	Chipbreaker	Designation	Corner Radius	Coating													No Coated	Cermets	Coated Cermets							
				TP710	TP720	TP7110	TP7220	TM810	TM820	TM8110	TM8220	TK910	TK920	TMS3115	TMS3125	TH510				TJ15	TJ20U	TN320	TC580	TC230	GT601	GT301
Finishing		VNMG160404-PF	0.4	●	●																					
		VNMG160408-PF	0.8	●	●																					
		VNMG220404-PF	0.4	●	●																					
		VNMG220408-PF	0.8	●	●																					
Medium Cutting		VNMG160404-PM	0.4	●	●																					
		VNMG160408-PM	0.8	●	●																					
		VNMG160412-PM	1.2	●	●																					
		VNMG160404-FM	0.4			●	●																			
		VNMG160408-FM	0.8			●	●																			
		VNMG160404-SF	0.4																				●			
VNMG160408-SF	0.8																				●					

● In Stock ○ Inquiry Each Time

External Toolholders: P43
Internal Toolholders: P52, P60

TurnLine Insert
Negative Type

● :Continuous Cutting ● :Light Interrupted Cutting

Application	Chipbreaker	Designation	Corner Radius	Coating													No Coated	Cermets	Coated Cermets							
				TP710	TP720	TP7110	TP7220	TM810	TM820	TM8110	TM8220	TK910	TK920	TMS3115	TMS3125	TH510				TJ15	TJ20U	TN320	TC580	TC230	GT601	GT301
				Medium Cutting		VNMG160404-GM	0.4	●	●	●	●														●	●
VNMG160408-GM	0.8							●	●	○																
	VNMG160404-MP	0.4							●	●																
	VNMG160408-MP	0.8						●	●	○																
	VNMG160404-MK	0.4									●	●														
	VNMG160408-MK	0.8									●	●														
	VNMG160412-MK	1.2									●	●														
	VNMG160404-UG	0.4														○										
	VNMG160408-UG	0.8														○										
	VNMG160404-PU	0.4																				●				
	VNMG160408-PU	0.8																				●				

● In Stock ○ Inquiry Each Time

External Toolholders:P43
Internal Toolholders:P52,P60





Application	Chipbreaker	Designation	Corner Radius	Coated													No Coated	Cermets	Coated Cermets							
				TP710	TP720	TP7110	TP7220	TM810	TM820	TM8110	TM8220	TK910	TK920	TMS3115	TMS3125	TH510				TJ15	TJ20U	TN320	TC580	TC230	GT601	GT301
				Finishing		WNMG060404-PF	0.4	●	●																	
WNMG060408-PF	0.8	●	●																							
WNMG080404-PF	0.4	●	●																							
WNMG080408-PF	0.8	●	●																							

● In Stock ○ Inquiry Each Time

External Toolholders:P44
Internal Toolholders:P52,P60

TurnLine Insert
Negative Type

● :Continuous Cutting ● :Light Interrupted Cutting

Application		Chipbreaker	Designation	Corner Radius	Coating													No Coated	Cermets		Coated Cermets			
					TP710	TP720	TP7110	TP7220	TM810	TM820	TM8110	TM8220	TK910	TK920	TMS3115	TMS3125	TH510		TJ15	TJ20U		TN320	TC580	TC230
Insert	WN	Trigon80°	P	Steel	●	●	●	●										●	●	●	●	●	●	
			M	Stainless					●	●	●								●	●				
		Negative	K	Cast Iron								●	●								●	●	●	●
			N	Non-ferrous															●					
			S	Superalloys										●	●									
with Hole	H	Hard Materials												●										
	External Toolholder	Medium Cutting		WNUMG080404-UG	0.4																			
Internal Toolholder	Medium Cutting		WNUMG080408-UG	0.8																				
			WNUMG080404-PU	0.4																		●		
Internal Toolholder	Medium Cutting		WNUMG080408-PU	0.8																		●		
			WNUMG080412-PU	1.2																			●	
			WNUMG080404-TQ	0.4																				●
Internal Toolholder	Medium Cutting		WNUMG080408-TQ	0.8																		●		
			WNUMG080412-TQ	1.2																			●	

● In Stock ○ Inquiry Each Time

External Toolholders:P44
Internal Toolholders:P52,P60

Insert
External Toolholder
Internal Toolholder
Therading
Parting ,Grooving
Miniature Tool

TurnLine Insert
Positive Type

● :Continuous Cutting ● :Light Interrupted Cutting

Application	Chipbreaker	Designation	Corner Radius	Coating													No Coated	Cermets	Coated Cermets																																																																																																																																									
				TP710	TP720	TP7110	TP7220	TM810	TM820	TM8110	TM8220	TK910	TK920	TMS3115	TMS3125	TH510				TJ15	TJ20U	TN320	TC580	TC230	GT601	GT301																																																																																																																																		
				<table border="1"> <tr> <td rowspan="5">CC</td> <td>Rhombic 80°</td> <td>P</td> <td>Steel</td> <td>●</td><td>●</td><td>●</td><td>●</td><td></td><td></td><td></td><td></td><td></td><td></td><td></td><td></td><td></td><td></td><td>●</td><td>●</td><td>●</td><td>●</td><td>●</td><td>●</td> </tr> <tr> <td></td> <td>M</td> <td>Stainless</td> <td></td><td></td><td></td><td></td><td>●</td><td>●</td><td>●</td><td>●</td><td></td><td></td><td></td><td></td><td></td><td></td><td>●</td><td>●</td><td></td><td></td><td></td><td></td> </tr> <tr> <td rowspan="2">Positive 7°</td> <td>K</td> <td>Cast Iron</td> <td></td><td></td><td></td><td></td><td></td><td></td><td></td><td></td><td>●</td><td>●</td><td></td><td></td><td></td><td></td><td></td><td></td><td>●</td><td>●</td><td>●</td><td>●</td> </tr> <tr> <td>N</td> <td>Non-ferrous</td> <td></td><td></td><td></td><td></td><td></td><td></td><td></td><td></td><td></td><td></td><td></td><td></td><td></td><td></td><td></td><td>●</td><td></td><td></td><td></td><td></td> </tr> <tr> <td rowspan="2">with Hole</td> <td>S</td> <td>Superalloys</td> <td></td><td></td><td></td><td></td><td></td><td></td><td></td><td></td><td></td><td>●</td><td>●</td><td></td><td></td><td></td><td></td><td></td><td></td><td></td><td></td><td></td> </tr> <tr> <td>H</td> <td>Hard Materials</td> <td></td><td></td><td></td><td></td><td></td><td></td><td></td><td></td><td></td><td></td><td></td><td>●</td><td></td><td></td><td></td><td></td><td></td><td></td><td></td><td></td> </tr> </table>																				CC	Rhombic 80°	P	Steel	●	●	●	●											●	●	●	●	●	●		M	Stainless					●	●	●	●							●	●					Positive 7°	K	Cast Iron									●	●							●	●	●	●	N	Non-ferrous																●					with Hole	S	Superalloys										●	●										H	Hard Materials												●				
CC	Rhombic 80°	P	Steel	●	●	●	●											●	●	●	●	●	●																																																																																																																																					
		M	Stainless					●	●	●	●							●	●																																																																																																																																									
	Positive 7°	K	Cast Iron									●	●							●	●	●	●																																																																																																																																					
		N	Non-ferrous																●																																																																																																																																									
	with Hole	S	Superalloys										●	●																																																																																																																																														
H		Hard Materials												●																																																																																																																																														
Finishing to Medium Cutting		CCGT09T301RL-15U	0.1																																																																																																																																																									
		CCGT09T302RL-15U	0.2																				●																																																																																																																																					
		CCGT09T304RL-15U	0.4																				●																																																																																																																																					
		CCGT09T302-AL	0.2																●																																																																																																																																									
		CCGT09T304-AL	0.4																●																																																																																																																																									
		CCGT09T308-AL	0.8																●																																																																																																																																									
		CCGT120402-AL	0.2																●																																																																																																																																									
		CCGT120404-AL	0.4																●																																																																																																																																									
		CCGT120408-AL	0.8																●																																																																																																																																									

● In Stock ○ Inquiry Each Time

External Toolholders:P45
Internal Toolholders:P53,P61









Application	Chipbreaker	Designation	Corner Radius	Coating													No Coated	Cermets	Coated Cermets																																																																																																																																								
				TP710	TP720	TP7110	TP7220	TM810	TM820	TM8110	TM8220	TK910	TK920	TMS3115	TMS3125	TH510				TJ15	TJ20U	TN320	TC580	TC230	GT601	GT301																																																																																																																																	
				<table border="1"> <tr> <td rowspan="5">DC</td> <td>Rhombic 55°</td> <td>P</td> <td>Steel</td> <td>●</td><td>●</td><td>●</td><td>●</td><td></td><td></td><td></td><td></td><td></td><td></td><td></td><td></td><td></td><td></td><td>●</td><td>●</td><td>●</td><td>●</td><td>●</td> </tr> <tr> <td></td> <td>M</td> <td>Stainless</td> <td></td><td></td><td></td><td></td><td>●</td><td>●</td><td>●</td><td>●</td><td></td><td></td><td></td><td></td><td></td><td></td><td>●</td><td>●</td><td></td><td></td><td></td><td></td> </tr> <tr> <td rowspan="2">Positive 7°</td> <td>K</td> <td>Cast Iron</td> <td></td><td></td><td></td><td></td><td></td><td></td><td></td><td></td><td>●</td><td>●</td><td></td><td></td><td></td><td></td><td></td><td></td><td>●</td><td>●</td><td>●</td><td>●</td> </tr> <tr> <td>N</td> <td>Non-ferrous</td> <td></td><td></td><td></td><td></td><td></td><td></td><td></td><td></td><td></td><td></td><td></td><td></td><td></td><td></td><td></td><td>●</td><td></td><td></td><td></td><td></td> </tr> <tr> <td rowspan="2">with Hole</td> <td>S</td> <td>Superalloys</td> <td></td><td></td><td></td><td></td><td></td><td></td><td></td><td></td><td></td><td>●</td><td>●</td><td></td><td></td><td></td><td></td><td></td><td></td><td></td><td></td><td></td> </tr> <tr> <td>H</td> <td>Hard Materials</td> <td></td><td></td><td></td><td></td><td></td><td></td><td></td><td></td><td></td><td></td><td></td><td>●</td><td></td><td></td><td></td><td></td><td></td><td></td><td></td><td></td> </tr> </table>																				DC	Rhombic 55°	P	Steel	●	●	●	●											●	●	●	●	●		M	Stainless					●	●	●	●							●	●					Positive 7°	K	Cast Iron									●	●							●	●	●	●	N	Non-ferrous																●					with Hole	S	Superalloys										●	●										H	Hard Materials												●				
DC	Rhombic 55°	P	Steel	●	●	●	●											●	●	●	●	●																																																																																																																																					
		M	Stainless					●	●	●	●							●	●																																																																																																																																								
	Positive 7°	K	Cast Iron									●	●							●	●	●	●																																																																																																																																				
		N	Non-ferrous																●																																																																																																																																								
	with Hole	S	Superalloys										●	●																																																																																																																																													
H		Hard Materials												●																																																																																																																																													
Finishing to Medium Cutting		DCMT070204-PS	0.4		●							●	●									●																																																																																																																																					
		DCMT070208-PS	0.8		●							●	●																																																																																																																																														
		DCMT11T304-PS	0.4	●	●								●	●									●																																																																																																																																				
		DCMT11T308-PS	0.8	●	●								●	●																																																																																																																																													
		DCMT150408-PS	0.8											●																																																																																																																																													
		DCMT070202-MM	0.2									●			●																																																																																																																																												
		DCMT070204-MM	0.4								●	●			●								●																																																																																																																																				
		DCMT070208-MM	0.8								●	●			●																																																																																																																																												
		DCMT11T302-MM	0.2																				●																																																																																																																																				
		DCMT11T304-MM	0.4							●	●	○			●								●																																																																																																																																				
		DCMT11T308-MM	0.8							●	●	○			●								●																																																																																																																																				
		DCMT11T304-KS	0.4		●							●	●																																																																																																																																														
		DCMT11T308-KS	0.8		●							●	●																																																																																																																																														
		DCMT070202-UA	0.2																				○																																																																																																																																				
DCMT070204-UA		0.4																				○																																																																																																																																					
DCMT11T302-UA		0.2																				○																																																																																																																																					
DCMT11T304-UA		0.4																				○																																																																																																																																					

● In Stock ○ Inquiry Each Time

External Toolholders:P45
Internal Toolholders:P53,P61

**TurnLine Insert
Positive Type**

● :Continuous Cutting ● :Light Interrupted Cutting

Application	Chipbreaker	Designation	Corner Radius	Coating													No Coated	Cermet	Coated Cermet							
				TP710	TP720	TP7110	TP7220	TM810	TM820	TM8110	TM8220	TK910	TK920	TMS3115	TMS3125	TH510				TJ15	TJ20U	TN320	TC580	TC230	GT601	GT301
Finishing to Medium Cutting		DCMT070202-UT	0.2	●	●	●	●											●	●	●	●	●	●			
		DCMT070204-UT	0.4																							
		DCMT11T302-UT	0.2																							
		DCMT11T304-UT	0.4																							
		DCGT070201R/L-15V	0.1																●							
		DCGT070202R/L-15V	0.2																	●						
		DCGT070204R/L-15V	0.4																		●					
		DCGT11T3003R/L-15V	0.03																	●						
		DCGT11T3005R/L-15V	0.05																	●						
		DCGT11T301R/L-15V	0.1																	●						
		DCGT11T302R/L-15V	0.2																	●						
		DCGT11T304R/L-15V	0.4																	●						
		DCGT070201R/L-12U	0.1																●							
		DCGT070202R/L-12U	0.2																	●						
		DCGT070204R/L-12U	0.4																	●						
		DCGT11T3005R/L-15U	0.05																	●						
		DCGT11T301R/L-15U	0.1																	●						
		DCGT11T302R/L-15U	0.2																	●						
		DCGT11T304R/L-15U	0.4																	●						
		DCGT11T3005R/L-16X	0.05																	●						
		DCGT11T301R/L-16X	0.1																	●						
		DCGT11T302R/L-16X	0.2																	●						
		DCGT11T304R/L-16X	0.4																	●						
			DCGT070201R/L-12U	0.1																	●					
	DCGT070202R/L-12U		0.2																	●						
	DCGT070204R/L-12U		0.4																	●						
			DCGT0702005R/L-15V	0.05																	●					
		DCGT070201R/L-15V	0.1																	●						
		DCGT070202R/L-15V	0.2																	●						
		DCGT070204R/L-15V	0.4																	●						
		DCGT11T302R/L-15V	0.2																	●						
		DCGT11T304R/L-15V	0.4																	●						
		DCGT070201R/L-15M	0.1																	●						
		DCGT070202R/L-15M	0.2																	●						
		DCGT070204R/L-15M	0.4																	●						
		DCGT11T301R/L-15M	0.1																	●						
		DCGT11T302R/L-15M	0.2																	●						
		DCGT11T304R/L-15M	0.4																	●						

● In Stock ○ Inquiry Each Time



External Toolholders:P45
Internal Toolholders:P53,P61

Insert
External Toolholder
Internal Toolholder
Threading
Parting, Grooving
Miniature Tool

TurnLine Insert
Negative Type

Insert
External Toolholder
Internal Toolholder
Threading
Parting, Grooving
Miniature Tool

● :Continuous Cutting ● :Light Interrupted Cutting

Application		Chipbreaker	Designation	Corner Radius	Coating													No Coated	Cermet	Coated Cermet				
					TP710	TP720	TP7110	TP7220	TM810	TM820	TM8110	TM8220	TK910	TK920	TMS3115	TMS3125	TH510				TJ15	TJ20U	TN320	TC580
Finishing to Medium Cutting		TPMT110202-MM	0.2	●	●	●	●											●	●	●	●	●	●	
		TPMT110204-MM	0.4							●		●												
		TPGH080202R/L-15K	0.2																●					
		TPGH080204R/L-15K	0.4																●					
		TPGH090201R/L-15K	0.1														●							
		TPGH090202R/L-15K	0.2															●						
		TPGH090204R/L-15K	0.4															●						
		TPGH110302R/L-15K	0.2															●						
		TPGH110304R/L-15K	0.4															●						
		TPGH080201R/L-15K	0.1																●					
		TPGH080202R/L-15K	0.2																●					
		TPGH080204R/L-15K	0.4																●					
		TPGH090201R/L-15K	0.1																●					
		TPGH090202R/L-15K	0.2																●					
		TPGH090204R/L-15K	0.4																●					
		TPGH110302R/L-15K	0.2																●					
		TPGH110304R/L-15K	0.4																●					
	TPGH110202R/L-15K	0.2																●						
	TPGH110204R/L-15K	0.4																●						

● In Stock ○ Inquiry Each Time

Internal Toolholders:P56,P63

● :Continuous Cutting ● :Light Interrupted Cutting

Application		Chipbreaker	Designation	Corner Radius	Coating													No Coated	Cermet	Coated Cermet			
					TP710	TP720	TP7110	TP7220	TM810	TM820	TM8110	TM8220	TK910	TK920	TMS3115	TMS3125	TH510				TJ15	TJ20U	TN320
Medium Cutting		VBMT160404-PS	0.4	●	●																●	●	●
		VBMT160408-PS	0.8	●	●																	●	

● In Stock ○ Inquiry Each Time

External Toolholders:P48

Internal Toolholders:P57,P64

TurnLine Ceramic Insert

TurnLine ceramic insert is in good wear-resistance and shock-resistance in high speed cutting. Pure raw materials give stability and fine microstructure to the products. Shaped bodies are completely condensed so that the finished goods are strong and resistant against fracture and wear .

- Improved work efficiency by increasing cutting speed on extremely higher than carbide inserts.
- Longer tool life through excellent wear resistance.
- Precise cutting and superior surface roughness.

Grade	Workpiece Material	Advantages
K30G	Gray Cast Iron (FC)	Al ₂ O ₃ +TiCN Excellent wear resistance A basic choice for machining hardened steel and alloy steel
	Malleable (FCMB) Chilled Cast Iron	
KC30G	Carbon Steel	Al ₂ O ₃ +TiCN+TiN coated Excellent wear resistance Finishing for hardened steel and cast iron
	Alloy Steel	
	Bearing Steel	
H70G	Gray Cast Iron (FC)	Al ₂ O ₃ +ZrO ₂ Finishing, semi-finishing of cast iron and steel
	Steel (HRC45≤)	
C60G	Ductile Cast Iron	TiC+Al ₂ O ₃ High thermal shock resistance Usable with coolant Finishing for ductile cast iron

TurnLine Ceramic Insert

CN	Rhombic 80°	P	Steel	•	•	•						
		M	Stainless									
	Negative	K	Cast Iron	•	•	•	•					
		N	Non-ferrous									
	with Hole	S	Superalloys									
H		Hard Materials	•	•								
Application	Chipbreaker	Designation	Corner Radius	CERAMIC								
				K30G	KC30G	H70G	C60G					
Medium Cutting		CNGA120404	0.4	•	•	•	•					
		CNGA120408	0.8	•	•	•	•					
		CNGA120412	1.2	•	•		•					

External Toolholders:P39
Internal Toolholders:P51,P59

DN	Rhombic 55°	P	Steel	•	•	•						
		M	Stainless									
	Negative	K	Cast Iron	•	•	•	•					
		N	Non-ferrous									
	with Hole	S	Superalloys									
H		Hard Materials	•	•								
Application	Chipbreaker	Designation	Corner Radius	CERAMIC								
				K30G	KC30G	H70G	C60G					
Medium Cutting		DNGA150404	0.4	•	•	•	•					
		DNGA150408	0.8	•	•	•	•					

External Toolholders:P40
Internal Toolholders:P51,P59

SN	Square 90°	P	Steel	•	•	•						
		M	Stainless									
	Negative	K	Cast Iron	•	•	•	•					
		N	Non-ferrous									
	with Hole	S	Superalloys									
H		Hard Materials	•	•								
Application	Chipbreaker	Designation	Corner Radius	CERAMIC								
				K30G	KC30G	H70G	C60G					
Medium Cutting		SNGA120404	0.4	•	•	•	•					
		SNGA120408	0.8	•	•	•	•					

External Toolholders:P40
Internal Toolholders:P51



TurnLine Ceramic Insert

Insert
 External Toolholder
 Internal Toolholder
 Threading
 Parting, Grooving
 Miniature Tool

TN		Triangular 60°	P	Steel	•	•	•						
		Negative with Hole	M	Stainless									
K	Cast Iron		•	•	•	•							
N	Non-ferrous												
S	Superalloys												
		H	Hard Materials		•	•							
Application	Chipbreaker	Designation	Corner Radius	CERAMIC									
				K30G	KC30G	H70G	C60G						
Medium Cutting		TNGA160404	0.4	•	•	•	•						
		TNGA160408	0.8	•	•	•	•						
		TNGA160412	1.2	•	•		•						

External Toolholders:P42
Internal Toolholders:P52,P59

VN		Rhombic 35°	P	Steel	•	•	•						
		Negative with Hole	M	Stainless									
K	Cast Iron		•	•	•	•							
N	Non-ferrous												
S	Superalloys												
		H	Hard Materials		•	•							
Application	Chipbreaker	Designation	Corner Radius	CERAMIC									
				K30G	KC30G	H70G	C60G						
Medium Cutting		VNGA080404	0.4	•	•	•							
		VNGA080408	0.8	•	•	•							
		VNGA080412	1.2	•	•								

External Toolholders:P43
Internal Toolholders:P52,60

WN		Trigon 80°	P	Steel	•	•	•						
		Negative with Hole	M	Stainless									
K	Cast Iron		•	•	•	•							
N	Non-ferrous												
S	Superalloys												
		H	Hard Materials		•	•							
Application	Chipbreaker	Designation	Corner Radius	CERAMIC									
				K30G	KC30G	H70G	C60G						
Medium Cutting		WNGA080404	0.4	•	•	•							
		WNGA080408	0.8	•	•	•							
		WNGA080412	1.2	•	•								

External Toolholders:P44
Internal Toolholders:P52,60

Characteristics of Cubic Boron Nitride (CBN)

Cubic boron nitride (CBN) is an excellent tool material with high hardness, high heat resistance and high chemical inertness. It can be applied to difficult-to-machine materials such as hardened steel, cast iron, superalloy and powder metal. Due to its high temperature resistance, high hardness, strong cutting force and low friction coefficient, CBN inserts enable to produce workpieces with outstanding surface roughness and maintain long life, high efficiency and stable performance.

Grade	Application	Work Material
TBN3500	Heavy cutting	Excellent impact resistance and wear resistance: High nickel chrome High hardness alloy cast iron Grey cast iron High manganese steel
TBN7000	Semi-Finishing Finishing	Excellent overall performance with universal application: Grey cast iron Hardened cast iron Hardened steel over HRC45
TBS7000	Finishing	
TBN7200	Heavy cutting	Excellent wear resistance: Grey cast iron
TBS7200	Finishing	
TBN9500	Finishing	Hardened steel over HRC45
TBK7520	Finishing for continuous to light interrupted cutting	Grey cast iron Powder metallurgy
TBK9550	Finishing for continuous to light interrupted cutting	Bearing steel Carburized steel

Insert

External Toolholder



Internal Toolholder

Threading

Parting, Grooving

Miniature Tool

TurnLine CBN Insert
Negative Type



CN	Rhombic 80°	P	Steel	•			•					
	Negative	M	Stainless									
		K	Cast Iron	•	•	•	•	•	•	•	•	•
		N	Non-ferrous									
		S	Superalloys									
	with Hole	H	Hard Materials		•		•	•		•	•	
Application	Chipbreaker	Designation	Corner Radius	CBN								
				TBN3500	TBN7000	TBN7200	TBN9500	TBS7000	TBS7200	TBK7520	TBK9550	
Medium Cutting		CNMN120404	0.4	•	•	•	•					
		CNMN120408	0.8	•	•	•	•					
		CNMN120412	1.2	•	•	•	•					
		CNGA120404-4T	0.4						•	•		
		CNGA120408-4T	0.8						•	•		
		CNGA120412-4T	1.2						•	•		
		CNGA160404-4T	0.4						•	•		
		CNGA160408-4T	0.8						•	•		
		CNGA160412-4T	1.2						•	•		
		CNGA120404-2S	0.4								•	•
		CNGA120408-2S	0.8								•	•
		CNGA120412-2S	1.2								•	•

External Toolholders:P39
Internal Toolholders:P51,P59





SN	Square 90°	P	Steel	•			•					
	Negative	M	Stainless									
		K	Cast Iron	•	•	•	•	•	•	•	•	
		N	Non-ferrous									
		S	Superalloys									
	without Hole	H	Hard Materials		•		•	•		•	•	
Application	Chipbreaker	Designation	Corner Radius	CBN								
				TBN3500	TBN7000	TBN7200	TBN9500	TBS7000	TBS7200	TBK7520	TBK9550	
Medium Cutting		SNMN090304	0.4	•	•	•	•					
		SNMN090308	0.8	•	•	•	•					
		SNMN090312	1.2	•	•	•	•					
		SNMN120404	0.4	•	•	•	•					
		SNMN120408	0.8	•	•	•	•					

External Toolholders:P40
Internal Toolholders:P51

TurnLine CBN Insert
Negative Type

Application		Chipbreaker	Designation	Corner Radius	CBN								
					TBN3500	TBN7000	TBN7200	TBN9500	TBS7000	TBS7200	TBK7520	TBK9550	
Medium Cutting			SNGA120404-8T	0.4	•				•				
			SNGA120408-8T	0.8					•	•			
			SNGA120412-8T	1.2					•	•			
		SNGA120404-2S	0.4								•	•	
		SNGA120408-2S	0.8								•	•	
		SNGA120412-2S	1.2								•	•	

External Toolholders:P40
Internal Toolholders:P51



Application		Chipbreaker	Designation	Corner Radius	CBN								
					TBN3500	TBN7000	TBN7200	TBN9500	TBS7000	TBS7200	TBK7520	TBK9550	
Medium Cutting			TNGN110304	0.4	•	•	•	•					
			TNGN110308	0.8	•	•	•	•					
			TNGN110312	1.2	•	•	•	•					
			TNGN160404	0.4	•		•	•					
			TNGN160408	0.8	•		•	•					
			TNGN160412	1.2	•		•	•					
		TNGA160404-6T	0.4					•	•				
		TNGA160408-6T	0.8					•	•				
		TNGA160412-6T	1.2					•	•				
		TNGA160404-3S	0.4								•	•	
		TNGA160408-3S	0.8								•	•	
		TNGA160412-3S	1.2								•	•	

External Toolholders:P42
Internal Toolholders:P52,P59





TurnLine CBN Insert
Negative Type

Application	Chipbreaker	Designation	Corner Radius	CBN							
				TBN3500	TBN7000	TBN7200	TBN9500	TBS7000	TBS7200	TBK7520	TBK9550
Medium Cutting		RNMN090300	-	●	●	●	●				
		RNMN120400	-	●	●	●	●				
		RNGN090300	-	●	●	●	●				
		RNGN120400	-	●	●	●	●				



Application	Chipbreaker	Designation	Corner Radius	CBN							
				TBN3500	TBN7000	TBN7200	TBN9500	TBS7000	TBS7200	TBK7520	TBK9550
Medium Cutting		WNMN080404	0.4	●	●	●	●				
		WNMN080408	0.8	●	●	●	●				
		WNMN080412	1.2	●	●	●	●				
		WNGA080404-6T	0.4					●	●		
		WNGA080408-6T	0.8					●	●		
		WNGA080412-6T	1.2					●	●		
		WNGA060404-3S	0.4							●	●
		WNGA060408-3S	0.8							●	●
		WNGA080404-3S	0.4							●	●
		WNGA080408-3S	0.8							●	●
		WNGA080412-3S	1.2							●	●

External Toolholders:P44
Internal Toolholders:P52,P60

TurnLine CBN Insert
Positive Type

Application		Chipbreaker	Designation	Corner Radius	CBN							
					TBN3500	TBN7000	TBN7200	TBN9500	TBS7000	TBS7200	TBK7520	TBK9550
Medium Cutting			CCGW09T304-2T	0.4					●	●		
			CCGW09T308-2T	0.8					●	●		
			CCGW09T312-2T	1.2					●	●		
			CCGW120404-2T	0.4					●	●		
			CCGW120408-2T	0.8					●	●		
			CCGW120412-2T	1.2					●	●		
			CCGW09T304-2S	0.4							●	●
			CCGW09T308-2S	0.8							●	●
			CCGW09T312-2S	1.2							●	●
			CCGW120404-2S	0.4							●	●
			CCGW120408-2S	0.8							●	●
			CCGW120412-2S	1.2							●	●

External Toolholders:P45
Internal Toolholders:P53,P61

Application		Chipbreaker	Designation	Corner Radius	CBN							
					TBN3500	TBN7000	TBN7200	TBN9500	TBS7000	TBS7200	TBK7520	TBK9550
Medium Cutting			DCGW11T304-2T	0.4					●	●		
			DCGW11T308-2T	0.8					●	●		
			DCGW11T312-2T	1.2					●	●		
			DCGW11T304-2S	0.4							●	●
			DCGW11T308-2S	0.8							●	●

External Toolholders:P45
Internal Toolholders:P53,P61



Insert
External Toolholder
Internal Toolholder
Threading
Parting, Grooving
Miniature Tool

TurnLine CBN Insert
Positive Type

Insert
 External Toolholder
 Internal Toolholder
 Threading
 Parting, Grooving
 Miniature Tool



TC		Triangular 60°	P	Steel	•			•				
		Positive 7° with Hole	M	Stainless								
K	Cast Iron		•	•	•	•	•	•	•	•	•	•
N	Non-ferrous											
S	Superalloys											
		H	Hard Materials		•		•	•		•	•	
Application	Chipbreaker	Designation	Corner Radius	CBN								
				TBN3500	TBN7000	TBN7200	TBN9500	TBS7000	TBS7200	TBK7520	TBK9550	
Medium Cutting		TCGW110304-3T	0.4					•	•			
		TCGW110308-3T	0.8					•	•			
		TCGW110312-3T	1.2					•	•			

External Toolholders:P48
Internal Toolholders:P55,P63

VB		Rhombic 35°	P	Steel	•			•				
		Positive 5° with Hole	M	Stainless								
K	Cast Iron		•	•	•	•	•	•	•	•	•	•
N	Non-ferrous											
S	Superalloys											
		H	Hard Materials		•		•	•		•	•	
Application	Chipbreaker	Designation	Corner Radius	CBN								
				TBN3500	TBN7000	TBN7200	TBN9500	TBS7000	TBS7200	TBK7520	TBK9550	
Medium Cutting		VBGW160404-2T	0.4					•	•			
		VBGW160408-2T	0.8					•	•			
		VBGW160412-2T	1.2					•	•			
		VBGW160404-2S	0.4								•	•
		VBGW160408-2S	0.8								•	•
		VBGW160412-2S	1.2								•	•

External Toolholders:P48
Internal Toolholders:P57,P64

TurnLine CBN Insert
Positive Type

VC		Rhombic 35°	P	Steel	•			•				
		Positive 7°	M	Stainless								
with Hole	K		Cast Iron	•	•	•	•	•	•	•	•	•
	N	Non-ferrous										
	S	Superalloys										
		H	Hard Materials		•		•	•		•	•	
Application	Chipbreaker	Designation	Corner Radius	CBN								
				TBN3500	TBN7000	TBN7200	TBN9500	TBS7000	TBS7200	TBK7520	TBK9550	
Medium Cutting		VCGW160404-2T	0.4					•	•			
		VCGW160408-2T	0.8					•	•			
		VCGW160412-2T	1.2					•	•			
		VCGW160404-2S	0.4								•	•
		VCGW160408-2S	0.8								•	•
		VCGW160412-2S	1.2								•	•

External Toolholders: P49
Internal Toolholders: P57, P65

Insert
External Toolholder
Internal Toolholder
Threading
Parting, Grooving
Miniature Tool

Insert
External Toolholder
Internal Toolholder
Threading
Parting, Grooving
Miniature Tool

Polycrystalline Diamond (PCD)

- Polycrystalline diamond material is a synthetic diamond sintered under high temperatures and pressures. PCD (Polycrystalline diamond) is ideal for non-ferrous metals and non-metals.
- Applicable for non-ferrous metals, non-metals turning, milling and other various type of cutting.
 - Long tool life due to extreme hardness.
 - Capable of high cutting speeds which increases cutting productivity.
 - Reduced edge build-up allows for high precision cutting.
 - Diversified applications for cutting of non-ferrous materials and non-metals.

Grade	Workpiece Material	Advantages
DA100	Pure Aluminum	Good wear resistance and toughness, good grindability.
DA150	High-gloss Aluminum	Cutting edge strength, wear resistance, fracture resistance, good edge-sharpening performance and long, stable tool life.
DA200	Die-cast Aluminum	Superior abrasive wear resistance and toughness due to high density PCD with mixed rough and fine grains.
DC200	Carbon Fiber	Good edge-sharpening performance and long, stable tool life.

TurnLine PCD Insert
Negative Type

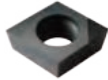
CN		Rhombic 80°	P	Steel															
		Negative	M	Stainless															
			K	Cast Iron															
			N	Non-ferrous	•	•	•	•											
			S	Superalloys															
		with Hole	H	Hard Materials															
Application	Chipbreaker	Designation	Corner Radius	PCD															
Medium Cutting		CNGA120404	0.4	•	•	•	•												
		CNGA120408	0.8	•	•	•	•												
		CNGA120412	1.2	•	•	•	•												

External Toolholders:P39
Internal Toolholders:P51,P59

DN		Rhombic 55°	P	Steel															
		Negative	M	Stainless															
			K	Cast Iron															
			N	Non-ferrous	•	•	•	•											
			S	Superalloys															
		with Hole	H	Hard Materials															
Application	Chipbreaker	Designation	Corner Radius	PCD															
Medium Cutting		DNGA150404	0.4	•	•	•	•												
		DNGA150408	0.8	•	•	•	•												

External Toolholders:P40
Internal Toolholders:P51,P59

SN		Square 90°	P	Steel															
		Negative	M	Stainless															
			K	Cast Iron															
			N	Non-ferrous	•	•	•	•											
			S	Superalloys															
		with Hole	H	Hard Materials															
Application	Chipbreaker	Designation	Corner Radius	PCD															
Medium Cutting		SNGA120404	0.4	•	•	•	•												
		SNGA120408	0.8	•	•	•	•												

External Toolholders:P40
Internal Toolholders:P51

Insert
External Toolholder
Internal Toolholder
Threading
Parting / Grooving
Miniature Tool

TurnLine PCD Insert
Negative Type

TN		Triangular 60°	P	Steel										
		Negative with Hole	M	Stainless										
K	Cast Iron													
N	Non-ferrous		•	•	•	•								
S	Superalloys													
		H	Hard Materials											
Application	Chipbreaker	Designation	Corner Radius	PCD										
				DA100	DA150	DA200	DC200							
Medium Cutting		TNGA160404	0.4	•	•	•	•							
		TNGA160408	0.8	•	•	•	•							
		TNGA160412	1.2	•	•	•	•							

External Toolholders:P42
Internal Toolholders:P52,P59

WN		Trigon 80°	P	Steel										
		Negative with Hole	M	Stainless										
K	Cast Iron													
N	Non-ferrous		•	•	•	•								
S	Superalloys													
		H	Hard Materials											
Application	Chipbreaker	Designation	Corner Radius	PCD										
				DA100	DA150	DA200	DC200							
Medium Cutting		WNGA080404	0.4	•	•	•	•							
		WNGA080408	0.8	•	•	•	•							
		WNGA080412	1.2	•	•	•	•							

External Toolholders:P44
Internal Toolholders:P52,P60

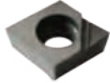
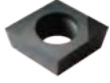

TurnLine PCD Insert
Positive Type

Application		Chipbreaker	Designation	Corner Radius	PCD								
					DA100	DA150	DA200	DC200					
Finishing to Medium Cutting		CCGT060202	0.2	●	●	●	●						
		CCGT060204	0.4	●	●	●	●						
		CCGT060208	0.8	●	●	●	●						
		CCGT09T302	0.2	●	●	●	●						
		CCGT09T304	0.4	●	●	●	●						
		CCGT09T308	0.8	●	●	●	●						
		CCGT120402	0.2	●	●	●	●						
		CCGT120404	0.4	●	●	●	●						
		CCGT120408	0.8	●	●	●	●						
		CCGW060202	0.2	●	●	●	●						
		CCGW060204	0.4	●	●	●	●						
		CCGW060208	0.8	●	●	●	●						
		CCGW09T302	0.2	●	●	●	●						
		CCGW09T304	0.4	●	●	●	●						
		CCGW09T308	0.8	●	●	●	●						
		CCGW120402	0.2	●	●	●	●						
		CCGW120404	0.4	●	●	●	●						
		CCGW120408	0.8	●	●	●	●						

External Toolholders:P45
Internal Toolholders:P53,P61

Insert
External Toolholder
Internal Toolholder
Threading
Parting, Grooving
Miniature Tool

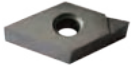

TurnLine PCD Insert
Positive Type

Application	Chipbreaker	Designation	Corner Radius	PCD							
				DA100	DA150	DA200	DC200				
Finishing to Medium Cutting		DCGT070202	0.2	●	●	●	●				
		DCGT070204	0.4	●	●	●	●				
		DCGT070208	0.8	●	●	●	●				
		DCGT090202	0.2	●	●	●	●				
		DCGT090204	0.4	●	●	●	●				
		DCGT090208	0.8	●	●	●	●				
		DCGT11T302	0.2	●	●	●	●				
		DCGT11T304	0.4	●	●	●	●				
	DCGT11T308	0.8	●	●	●	●					
		DCGW070202	0.2	●	●	●	●				
		DCGW070204	0.4	●	●	●	●				
		DCGW070208	0.8	●	●	●	●				
		DCGW090202	0.2	●	●	●	●				
		DCGW090204	0.4	●	●	●	●				
		DCGW090208	0.8	●	●	●	●				
		DCGW11T302	0.2	●	●	●	●				
		DCGW11T304	0.4	●	●	●	●				
			DCGW11T308	0.8	●	●	●	●			

External Toolholders:P45
Internal Toolholders:P53,P61

Insert
External Toolholder
Internal Toolholder
Therading
Parting ,Grooving
Miniature Tool



TurnLine PCD Insert
Positive Type

TC		Triangular60°	P	Steel										
			M	Stainless										
		Positive7°	K	Cast Iron										
			N	Non-ferrous	•	•	•	•						
		with Hole	S	Superalloys										
			H	Hard Materials										
Application	Chipbreaker	Designation	Corner Radius	PCD										
				DA100	DA150	DA200	DC200							
Finishing to Medium Cutting		TCGT060202	0.2	•	•	•	•							
		TCGT060204	0.4	•	•	•	•							
		TCGT080202	0.2	•	•	•	•							
		TCGT080204	0.4	•	•	•	•							
		TCGT090202	0.2	•	•	•	•							
		TCGT090204	0.4	•	•	•	•							
		TCGT090208	0.8	•	•	•	•							
		TCGT110202	0.2	•	•	•	•							
		TCGT110204	0.4	•	•	•	•							
		TCGT110208	0.8	•	•	•	•							
		TCGT16T304	0.4	•	•	•	•							
		TCGT16T308	0.8	•	•	•	•							
		TCGT160404	0.4	•	•	•	•							
		TCGT160408	0.8	•	•	•	•							
	TCGT160412	1.2	•	•	•	•								
		TCGW060202	0.2	•	•	•	•							
		TCGW060204	0.4	•	•	•	•							
		TCGW080202	0.2	•	•	•	•							
		TCGW080204	0.4	•	•	•	•							
		TCGW090202	0.2	•	•	•	•							
		TCGW090204	0.4	•	•	•	•							
		TCGW090208	0.8	•	•	•	•							
		TCGW110202	0.2	•	•	•	•							
		TCGW110204	0.4	•	•	•	•							
		TCGW110208	0.8	•	•	•	•							
		TCGW16T304	0.4	•	•	•	•							
TCGW16T308		0.8	•	•	•	•								
TCGW160404	0.4	•	•	•	•									
TCGW160408	0.8	•	•	•	•									
TCGW160412	1.2	•	•	•	•									

External Toolholders:P48
Internal Toolholders:P55,P63



Insert
External Toolholder
Internal Toolholder
Threading
Parting, Grooving
Miniature Tool

TurnLine PCD Insert
Positive Type



Application	Chipbreaker	Designation	Corner Radius	PCD							
				DA100	DA150	DA200	DC200				
Finishing to Medium Cutting		TPGH080202	0.2	●	●	●	●				
		TPGH080204	0.4	●	●	●	●				
		TPGH080208	0.8	●	●	●	●				
		TPGH090202	0.2	●	●	●	●				
		TPGH090204	0.4	●	●	●	●				
		TPGH090208	0.8	●	●	●	●				
		TPGH110302	0.2	●	●	●	●				
		TPGH110304	0.4	●	●	●	●				
		TPGH110308	0.8	●	●	●	●				
	TPGH160304	0.4	●	●	●	●					
		TPGW080202	0.2	●	●	●	●				
		TPGW080204	0.4	●	●	●	●				
		TPGW080208	0.8	●	●	●	●				
		TPGW090202	0.2	●	●	●	●				
		TPGW090204	0.4	●	●	●	●				
		TPGW090208	0.8	●	●	●	●				
		TPGW110302	0.2	●	●	●	●				
		TPGW110304	0.4	●	●	●	●				
		TPGW110308	0.8	●	●	●	●				
TPGW160304	0.4	●	●	●	●						
TPGW160308	0.8	●	●	●	●						

Internal Toolholders:P56,P63

TurnLine PCD Insert
Positive Type

Application		Chipbreaker	Designation	Corner Radius	PCD										
					DA100	DA150	DA200	DC200							
Finishing to Medium Cutting			VBGT110302	0.2	●	●	●	●							
			VBGT110304	0.4	●	●	●	●							
			VBGT110308	0.8	●	●	●	●							
			VBGT160404	0.4	●	●	●	●							
			VBGT160408	0.8	●	●	●	●							
				VBGW110302	0.2	●	●	●	●						
				VBGW110304	0.4	●	●	●	●						
				VBGW110308	0.8	●	●	●	●						
				VBGW160404	0.4	●	●	●	●						
				VBGW160408	0.8	●	●	●	●						

External Toolholders: P48
Internal Toolholders: P57, P64

Application		Chipbreaker	Designation	Corner Radius	PCD										
					DA100	DA150	DA200	DC200							
Finishing to Medium Cutting			VCGT110302	0.2	●	●	●	●							
			VCGT110304	0.4	●	●	●	●							
			VCGT110308	0.8	●	●	●	●							
			VCGT160404	0.4	●	●	●	●							
			VCGT160408	0.8	●	●	●	●							
				VCGW110302	0.2	●	●	●	●						
				VCGW110304	0.4	●	●	●	●						
				VCGW110308	0.8	●	●	●	●						
				VCGW160404	0.4	●	●	●	●						
				VCGW160408	0.8	●	●	●	●						

External Toolholders: P49
Internal Toolholders: P57, P65

Insert
External Toolholder
Internal Toolholder
Threading
Parting, Grooving
Miniature Tool

EXTERNAL TOOLHOLDER



Multi-clamp Toolholder ----- P39-P44



Screw-on Clamp Toolholder ----- P45-P50

INTERNAL TOOLHOLDER



Multi-clamp Toolholder ----- P51-P52



Screw-on Clamp Toolholder ----- P53-P58



Steel Boring Bar with Coolant Hole --- P59-P65

THREADING



Thread Insert & Toolholder ----- P66-P70



Thread Insert & Toolholder for Oil Pipe P71-P79

External Toolholder
Multi-clamp Toolholder

MCLNR/L



CN □□

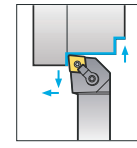
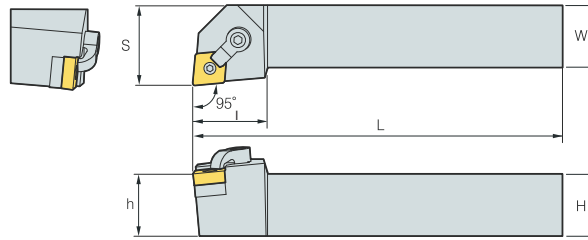

95°
R type insert

(mm)

Order No.	Dimension (mm)						Insert	Pin	Shim	Wrench	Screw	Clamp
	H	W	L	S	h	l						
MCLNR/L1616H12	16	16	100	20	16	25	CN..1204..	CTM617	MC1204	L2.5&L3	ML0625	HL1814
MCLNR/L2020K12	20	20	125	25	20	32						
MCLNR/L2525M12	25	25	150	32	25	32						
MCLNR/L3232P12	32	32	170	40	32	32						

MCKNR/L



CN □□

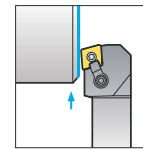
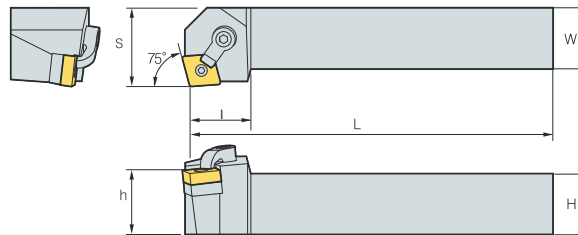

75°
R type insert

(mm)

Order No.	Dimension (mm)						Insert	Pin	Shim	Wrench	Screw	Clamp
	H	W	L	S	h	l						
MCKNR/L1616H12	16	16	100	20	16	25	CN..1204..	CTM617	MC1204	L2.5&L3	ML0625	HL1814
MCKNR/L2020K12	20	20	125	25	20	32						
MCKNR/L2525M12	25	25	150	32	25	32						
MCKNR/L3232P12	32	32	170	40	32	32						

MCMNN



CN □□

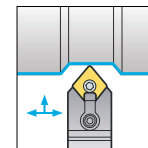
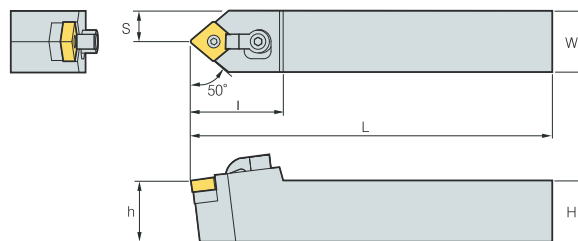

50°
R type insert

(mm)

Order No.	Dimension (mm)						Insert	Pin	Shim	Wrench	Screw	Clamp
	H	W	L	S	h	l						
MCMNN1616H12	16	16	100	8	16	25	CN..1204..	CTM617	MC1204	L2.5&L3	ML0625	HL1814
MCMNN2020K12	20	20	125	10	20	32						
MCMNN2525M12	25	25	150	12.5	25	32						
MCMNN3232P12	32	32	170	16	32	32						

Insert

External Toolholder

Internal Toolholder

Threading

Parting, Grooving

Miniature Tool

External Toolholder
Multi-clamp Toolholder

MDQNR/L

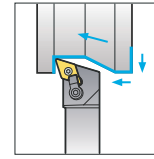
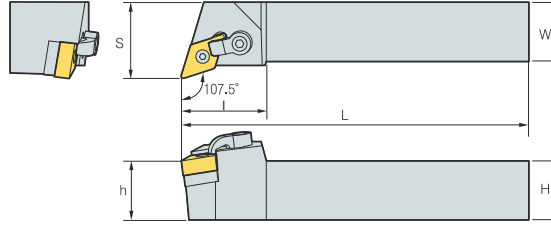

107.5°
R type insert

(mm)

Order No.	Dimension (mm)						Insert	Pin	Shim	Wrench	Screw	Clamp
	H	W	L	S	h	l						
MDQNR/L1616H11	16	16	100	20	16	28	DN..1104..	CTM513	MD1103	L2&L3		HL1814
MDQNR/L2020K11	20	20	125	25	20	32						
MDQNR/L2525M11	25	25	150	32	25	36						
MDQNR/L1616H15	16	16	100	20	16	28	DN..1504.. DN..1506..	CTM619	MD1506 MD1504	L2.5&L3	MI0625	HL2114
MDQNR/L2020K15	20	20	125	25	20	32						
MDQNR/L2525M15	25	25	150	32	25	36						
MDQNR/L3232P15	32	32	170	40	32	40						

MDJNR/L

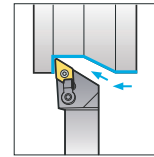
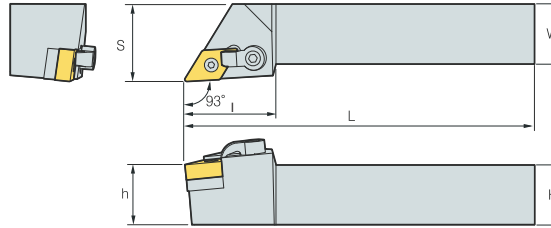

93°
R type insert

(mm)

Order No.	Dimension (mm)						Insert	Pin	Shim	Wrench	Screw	Clamp
	H	W	L	S	h	l						
MDJNR/L1616H11	16	16	100	20	16	28	DN..1104..	CTM513	MD1103	L2&L3		HL1814
MDJNR/L2020K11	20	20	125	25	20	32						
MDJNR/L2525M11	25	25	150	32	25	36						
MDJNR/L1616H15	16	16	100	20	16	28	DN..1504.. DN..1506..	CTM619	MD1506 MD1504	L2.5&L3	ML0625	HL2114
MDJNR/L2020K15	20	20	125	25	20	32						
MDJNR/L2525M15	25	25	150	32	25	36						
MDJNR/L3232P15	32	32	170	40	32	40						

MSBNR/L

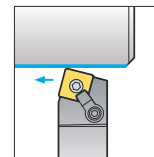
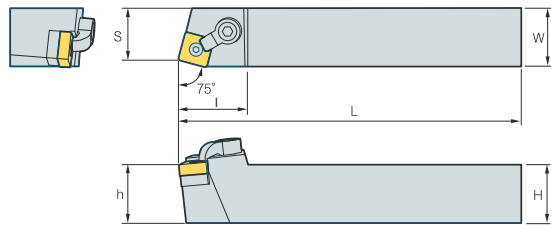

75°
R type insert

(mm)

Order No.	Dimension (mm)						Insert	Pin	Shim	Wrench	Screw	Clamp
	H	W	L	S	h	l						
MSBNR/L1616H12	16	16	100	14	16	28	SN..1204..	CTM617	MS1204	L2.5&L3	ML0625	HL1814
MSBNR/L2020K12	20	20	125	17	20	32						
MSBNR/L2525M12	25	25	150	22	25	32						
MSBNR/L3232P12	32	32	170	27	32	32						

External Toolholder
Multi-clamp Toolholder

MSKNR/L



SN □□

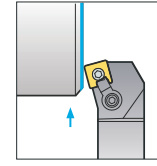
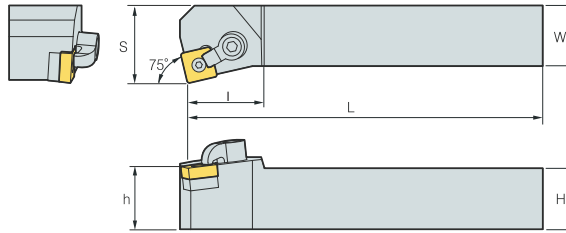

75°
R type insert

(mm)

Order No.	Dimension (mm)						Insert	Pin	Shim	Wrench	Screw	Clamp
	H	W	L	S	h	l						
MSKNR/L1616H12	16	16	100	20	16	28	SN..1204..	CTM617	MS1204	L2.5&L3	ML0625	HL1814
MSKNR/L2020K12	20	20	125	25	20	32						
MSKNR/L2525M12	25	25	150	32	25	32						
MSKNR/L3232P12	32	32	170	40	32	32						

MSRNR/L



SN □□

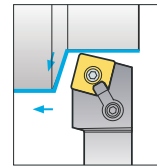
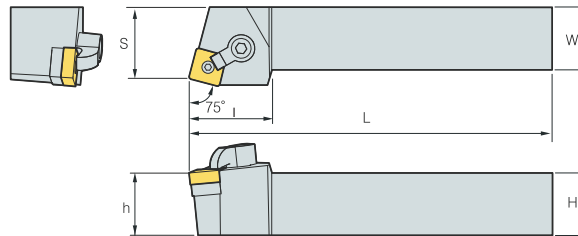

75°
R type insert

(mm)

Order No.	Dimension (mm)						Insert	Pin	Shim	Wrench	Screw	Clamp
	H	W	L	S	h	l						
MSRNR/L1616H12	16	16	100	17	16	28	SN..1204..	CTM617	MS1204	L2.5&L3	ML0625	HL1814
MSRNR/L2020K12	20	20	125	22	20	32						
MSRNR/L2525M12	25	25	150	27	25	32						
MSRNR/L3232P12	32	32	170	35	32	40						

MSSNR/L



SN □□

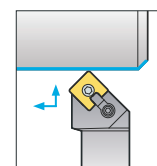
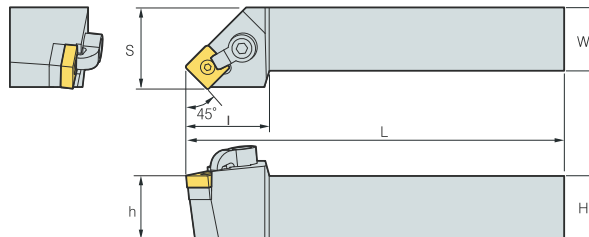

45°
R type insert

(mm)

Order No.	Dimension (mm)						Insert	Pin	Shim	Wrench	Screw	Clamp
	H	W	L	S	h	l						
MSSNR/L1616H12	16	16	100	20	16	28	SN..1204..	CTM617	MS1204	L2.5&L3	ML0625	HL1814
MSSNR/L2020K12	20	20	125	25	25	28						
MSSNR/L2525M12	25	25	150	32	25	32						
MSSNR/L3232P12	32	32	170	40	32	35						

Insert
External Toolholder
Internal Toolholder
Threading
Parting, Grooving
Miniature Tool

External Toolholder
Multi-clamp Toolholder

MSDNN



SN □□

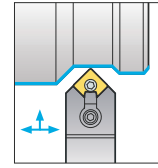
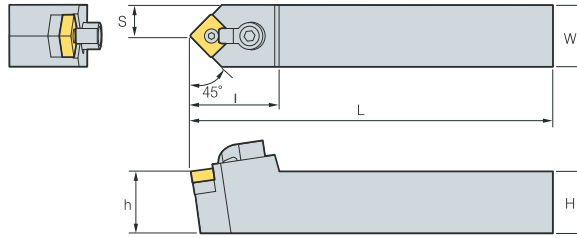

45°
R type insert

(mm)

Order No.	Dimension (mm)						Insert	Pin	Shim	Wrench	Screw	Clamp
	H	W	L	S	h	l						
MSDNN1616H12	16	16	100	8	16	28	SN..1204..	CTM617	MS1204	L2.5&L3	ML0625	HL1814
MSDNN2020K12	20	20	125	10	20	28						
MSDNN2525M12	25	25	150	12.5	25	32						
MSDNN3232P12	32	32	170	16	32	35						

MTJNR/L



TN □□

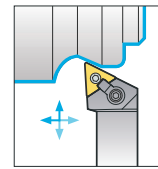
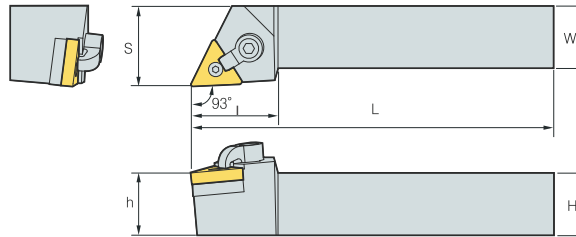

93°
R type insert

(mm)

Order No.	Dimension (mm)						Insert	Pin	Shim	Wrench	Screw	Clamp
	H	W	L	S	h	l						
MTJNR/L1616H16	16	16	100	20	16	28	TN..1604..	CTM513	MT1603	L2&L3	ML0625	HL1814
MTJNR/L2020K16	20	20	125	25	20	32						
MTJNR/L2525M16	25	25	150	32	25	32						
MTJNR/L3232P16	32	32	170	40	32	35						

External Toolholder
Multi-clamp Toolholder

MTENN



TN □□

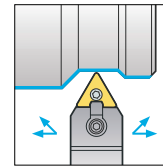
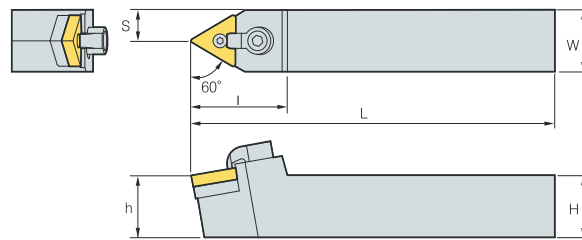

60°

R type insert

(mm)

Order No.	Dimension (mm)						Insert	Pin	Shim	Wrench	Screw	Clamp
	H	W	L	S	h	l						
MTENN1616H16	16	16	100	8	16	28	TN..1604..	CTM513	MT1603	L2&L3	ML0625	HL1814
MTENN2020K16	20	20	125	10	20	32						
MTENN2525M16	25	25	150	12.5	25	32						
MTENN3232P16	32	32	170	16	32	35						

MVQNR/L



VN □□

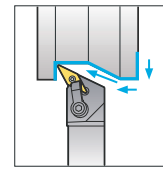
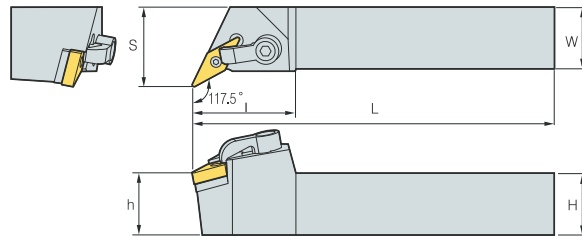

117.5°

R type insert

(mm)

Order No.	Dimension (mm)						Insert	Pin	Shim	Wrench	Screw	Clamp
	H	W	L	S	h	l						
MVQNR/L1616H16	16	16	100	20	16	20	VN..1604..	CTM513	MV1603	L2&L3	ML0625	HI2114
MVQNR/L2020K16	20	20	125	25	20	25						
MVQNR/L2525M16	25	25	150	32	25	32						
MVQNR/L3232P16	32	32	170	40	32	40						

MVJNR/L



VN □□

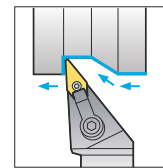
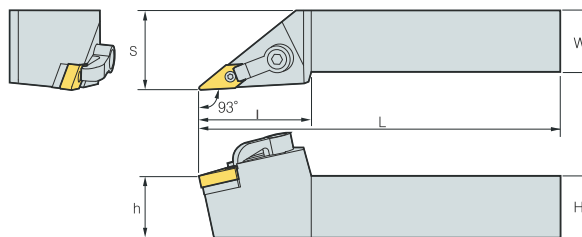

93°

R type insert

(mm)

Order No.	Dimension (mm)						Insert	Pin	Shim	Wrench	Screw	Clamp
	H	W	L	S	h	l						
MVJNR/L1616H16	16	16	100	20	16	32	VN..1604..	CTM513	MV1603	L2&L3	ML0625	HL2414
MVJNR/L2020K16	20	20	125	25	20	37						
MVJNR/L2525M16	25	25	150	32	25	37						
MVJNR/L3232P16	32	32	170	40	32	37						



External Toolholder
Multi-clamp Toolholder

MVVNN



VN □□

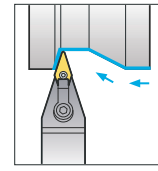
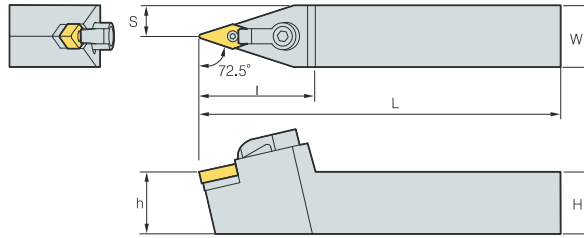

72.5°
R type insert

(mm)

Order No.	Dimension (mm)						Insert	Pin	Shim	Wrench	Screw	Clamp
	H	W	L	S	h	I						
MVVNN1616H16	16	16	100	8	16	40	VN..1604..	CTM513	MT1603	L2&L3	ML0625	HL2114
MVVNN2020K16	20	20	125	10	20	42						
MVVNN2525M16	25	25	150	12.5	25	42						
MVVNN3232P16	32	32	170	16	32	42						

MWLNR/L



WN □□

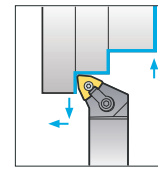
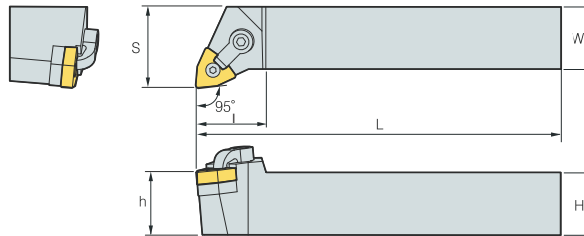

95°
R type insert

(mm)

Order No.	Dimension (mm)						Insert	Pin	Shim	Wrench	Screw	Clamp
	H	W	L	S	h	I						
MWLNR/L1616H06	16	16	100	20	16	32	WN..0604..	CTM513	MW0603	L2&L3	ML0625	HL1814
MWLNR/L2020K06	20	20	125	25	20	32						
MWLNR/L2525M06	25	25	150	32	25	32						
MWLNR/L1616H08	16	16	100	20	16	32	WN..0804..	CTM617	MW0804	L2.5&L3	ML0625	HL1814
MWLNR/L2020K08	20	20	125	25	20	32						
MWLNR/L2525M08	25	25	150	32	25	32						
MWLNR/L3232P08	32	32	170	40	32	32						

External Toolholder
Screw-on Clamp Toolholder

SCLCR/L



CC □□

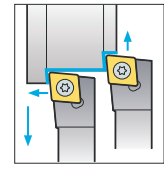
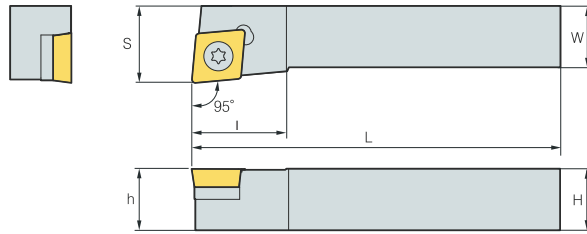

95°
R type insert

(mm)

Order No.	Dimension (mm)						Insert	Wrench	Screw
	H	W	L	S	h	l			
SCLCR/L0808H06	8	8	100	10	8	10	CC..0602..	T8	ST2506
SCLCR/L1010F06	10	10	80	16	10	10			
SCLCR/L1212H09	12	12	100	20	12	16	CC..09T3..	T15	ST3509
SCLCR/L1616H09	16	16	100	20	16	16			
SCLCR/L2020K09	20	20	125	25	20	16			
SCLCR/L2525M09	25	25	150	32	25	25	CC..1204..	T20	ST5012
SCLCR/L2020K12	20	20	125	25	20	25			
SCLCR/L2525M12	25	25	150	32	25	26			
SCLCR/L3232P12	32	32	170	40	32	30			

SCACR/L



CC □□

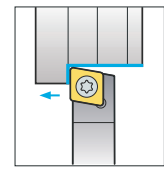
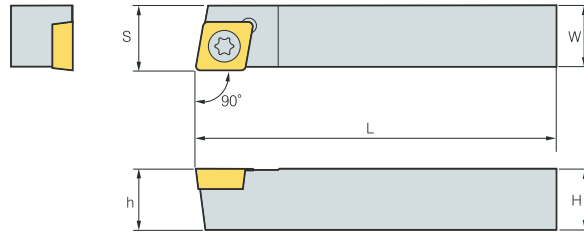

90°
R type insert

(mm)

Order No.	Dimension (mm)						Insert	Wrench	Screw
	H	W	L	S	h	l			
SCACR/L0808F06	8	8	80	8.5	8	-	CC..0602..	T8	ST2506
SCACR/L1010H06	10	10	100	10.5	10	-			
SCACR/L1212H06	12	12	100	12.5	12	-	CC..09T3..	T15	ST3509
SCACR/L1212H09	12	12	100	12.5	12	-			
SCACR/L1616H09	16	16	100	16.5	16	-			

SDJCR/L



DC □□

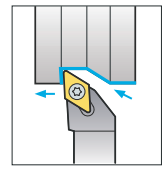
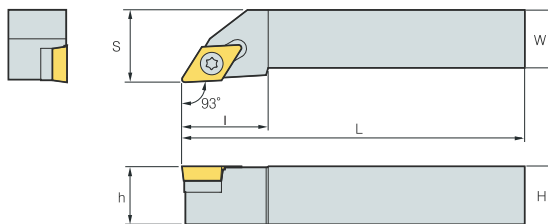

93°
R type insert

(mm)

Order No.	Dimension (mm)						Insert	Wrench	Screw
	H	W	L	S	h	l			
SDJCR/L0808H07	8	8	100	10	8	15	DC..0702..	T8	ST2508
SDJCR/L1010F07	10	10	80	12	10	15			
SDJCR/L1212F07	12	12	80	16	12	15			
SDJCR/L1616H07	16	16	100	20	16	18	DC..11T3..	T15	ST3509
SDJCR/L1212F11	12	12	80	16	12	15			
SDJCR/L1616H11	16	16	100	20	16	18			
SDJCR/L2020K11	20	20	125	25	20	24			
SDJCR/L2525M11	25	25	150	32	25	29			
SDJCR/L3232P11	32	32	170	40	32	40			

Insert

External Toolholder

Internal Toolholder

Threading

Parting, Grooving

Miniature Tool

External Toolholder
Screw-on Clamp Toolholder

SDACR/L

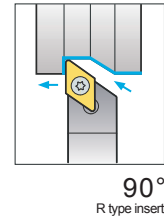
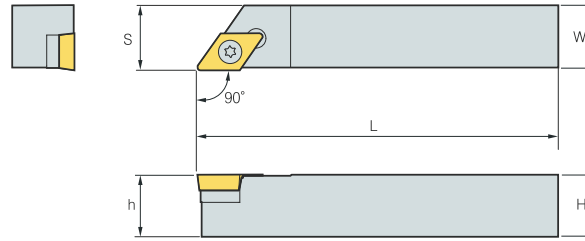

Order No.	Dimension (mm)						Insert	Wrench	Screw
	H	W	L	S	h	l			
SDACR/L0808F07	8	8	80	8.5	8	-	DC..0702..	T8	ST2508
SDACR/L1010F07	10	10	80	10.5	10	-			
SDACR/L1212F07	12	12	80	12.5	12	-			
SDACR/L1212H11	12	12	100	12.5	12	-	DC..11T3..	T15	ST3509
SDACR/L1616H11	16	16	100	16.5	16	-			
SDACR/L2020K11	20	20	125	20.5	20	-			
SDACR/L2525M11	25	25	150	25.5	25	-			

SDNCN

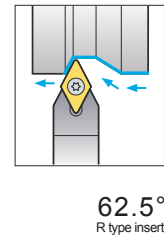
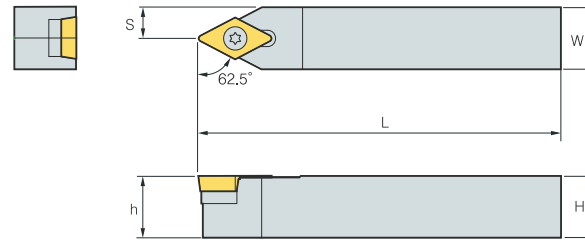

Order No.	Dimension (mm)						Insert	Wrench	Screw
	H	W	L	S	h	l			
SDNCN0808F07	8	8	80	4	8	-	DC..0702..	T8	ST2508
SDNCN1010F07	10	10	80	5	10	-			
SDNCN1212F07	12	12	80	6	12	-			
SDNCN1212H11	12	12	100	6	12	-	DC..11T3..	T15	ST3509
SDNCN1616H11	16	16	100	8	16	-			
SDNCN2020K11	20	20	125	10	20	-			

SSBCR/L

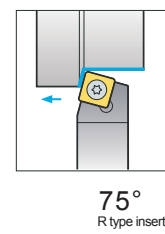
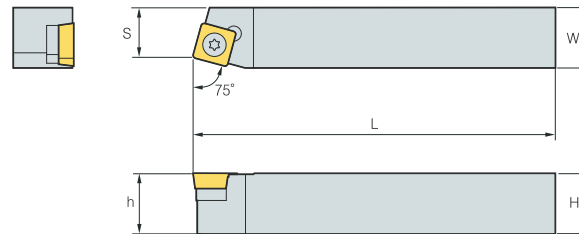

Order No.	Dimension (mm)						Insert	Wrench	Screw
	H	W	L	S	h	l			
SSBCR/L1212F09	12	12	80	11	12	-	SC..09T3..	T15	ST3509
SSBCR/L1616H09	16	16	100	13	16	-			
SSBCR/L2020K09	20	20	125	17	20	-			
SSBCR/L2525M09	25	25	150	22	25	-			
SSBCR/L2020K12	20	20	125	17	20	-	SC..1204..	T20	ST5012

External Toolholder
Screw-on Clamp Toolholder

SSKCR/L



SC □□

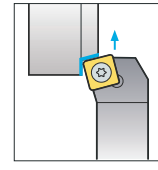
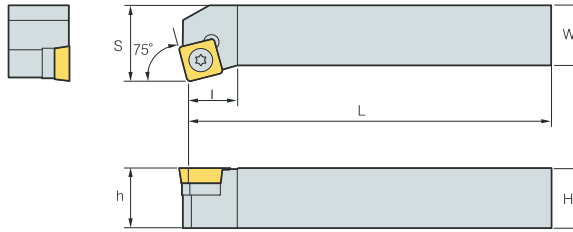

75°
R type insert

Order No.	Dimension (mm)						Insert	Wrench	Screw
	H	W	L	S	h	l			
SSKCR/L1616H09	16	16	100	20	16	13	SC..09T3..	T15	ST3509
SSKCR/L2020K09	20	20	125	25	20	16			

SSSCR/L



SC □□

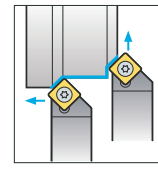
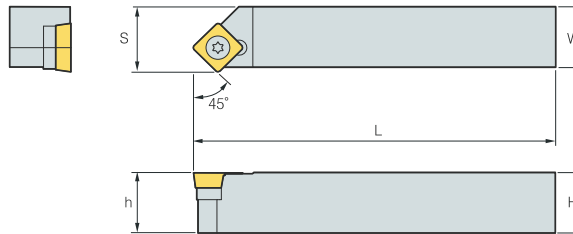

45°
R type insert

Order No.	Dimension (mm)						Insert	Wrench	Screw
	H	W	L	S	h	l			
SSSCR/L1616H09	16	16	100	17	16	-	SC..09T3..	T15	ST3509
SSSCR/L2020K09	20	20	125	21	20	-			
SSSCR/L2525M12	25	25	150	26	20	-	SC..1204..	T20	ST5012

SSDCN



SC □□

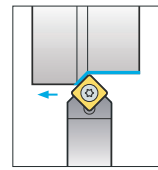
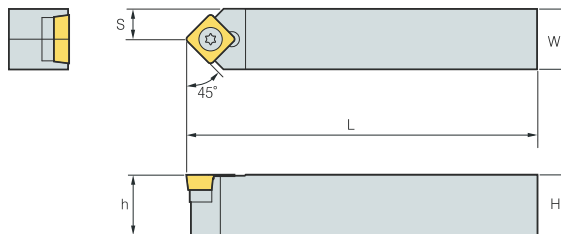

45°
R type insert

Order No.	Dimension (mm)						Insert	Wrench	Screw
	H	W	L	S	h	l			
SSDCN1212F09	12	12	80	6	12	-	SC..09T3..	T15	ST3509
SSDCN1616H09	16	16	100	8	16	-			
SSDCN2020K09	20	20	125	10	20	-			

Insert

External Toolholder

Internal Toolholder

Threading

Parting, Grooving

Miniature Tool

External Toolholder
Screw-on Clamp Toolholder

STGCR/L



TC □□

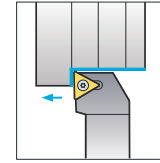
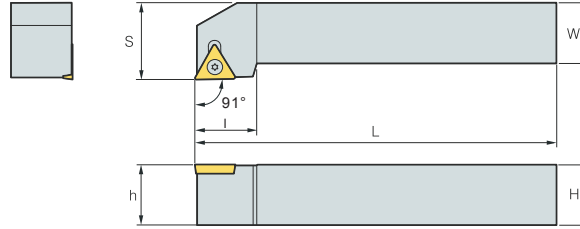

91°
R type insert

(mm)

Order No.	Dimension (mm)						Insert	Wrench	Screw
	H	W	L	S	h	l			
STGCR/L0808H09	8	8	100	10	8	9	TC..0902..	T8	ST2508
STGCR/L1010H09	10	10	100	12	10	12			
STGCR/L1212H11	12	12	100	16	12	14			
STGCR/L1616H11	16	16	100	20	16	20	TC..1102..	T8	ST2508
STGCR/L2020K16	20	20	125	25	20	25			
STGCR/L2525M16	25	25	150	32	25	27	TC..16T3..	T15	ST3509
STGCR/L3232P16	32	32	175	40	32	32			

SVJBR/L



VB □□

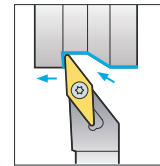
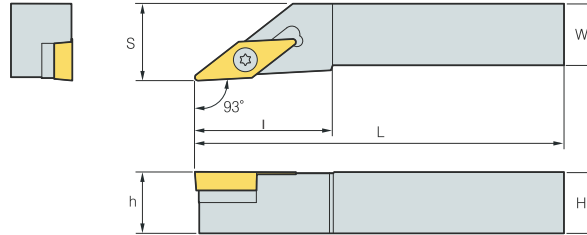

93°
R type insert

(mm)

Order No.	Dimension (mm)						Insert	Wrench	Screw
	H	W	L	S	h	l			
SVJBR/L1010H11	10	10	100	14	10	20	VB..1103..	T8	ST2508
SVJBR/L1212F11	12	12	80	16	12	25			
SVJBR/L1616H11	16	16	100	20	16	32			
SVJBR/L2020K11	20	20	125	25	20	32			
SVJBR/L2525M11	25	25	150	32	25	40			
SVJBR/L1616H16	16	16	100	20	16	32	VB..1604..	T15	ST3509
SVJBR/L2020K16	20	20	125	25	20	32			
SVJBR/L2525M16	25	25	150	32	25	40			
SVJBR/L3232P16	32	32	170	40	32	40			

External Toolholder
Screw-on Clamp Toolholder

SVVBN



VB □□

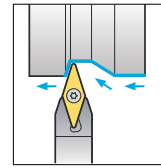
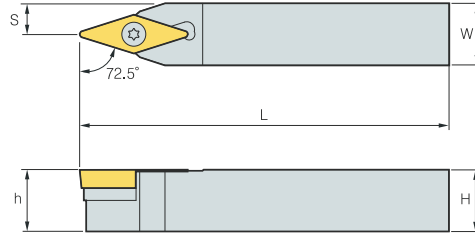

72.5°
R type insert

(mm)

Order No.	Dimension (mm)						Insert	Wrench	Screw
	H	W	L	S	h	l			
SVVBN1212F11	12	12	80	6	12	-	VB..1103..	T8	ST2508
SVVBN1616H11	16	16	100	8	16	-			
SVVBN2020K11	20	20	125	10	20	-			
SVVBN2525M11	25	25	150	12.5	25	-			
SVVBN1616H16	16	16	100	8	16	-	VB..1604..	T15	ST3509
SVVBN2020K16	20	20	125	10	20	-			
SVVBN2525M16	25	25	150	12.5	25	-			
SVVBN3232P16	32	32	170	16	32	-			

SVJCR/L



VC □□

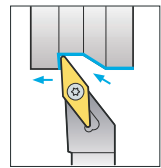
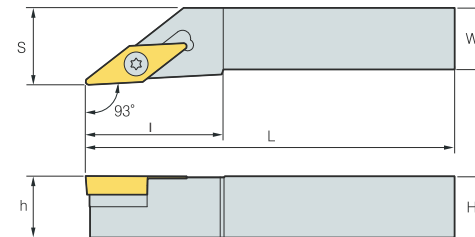

93°
R type insert

(mm)

Order No.	Dimension (mm)						Insert	Wrench	Screw
	H	W	L	S	h	l			
SVJCR/L1010H11	10	10	100	14	10	20	VC..1103..	T8	ST2508
SVJCR/L1212F11	12	12	80	16	12	25			
SVJCR/L1616H11	16	16	100	20	16	32			
SVJCR/L2020K11	20	20	125	25	20	32			
SVJCR/L2525M11	25	25	150	32	25	40	VC..1604..	T15	ST3509
SVJCR/L1616H16	16	16	100	20	16	32			
SVJCR/L2020K16	20	20	125	25	20	32			
SVJCR/L2525M16	25	25	150	32	25	40			
SVJCR/L3232P16	32	32	170	40	32	40			

External Toolholder
Screw-on Clamp Toolholder

SVVCN



VC □□

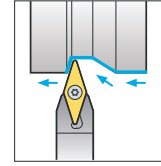
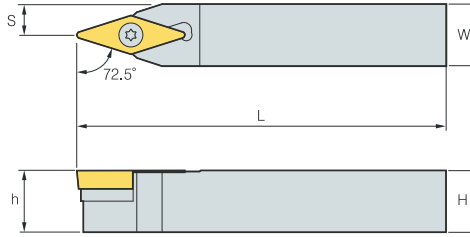

72.5°
R type insert

(mm)

Order No.	Dimension (mm)						Insert	Wrench	Screw
	H	W	L	S	h	l			
SVVCN1212F11	12	12	80	6	12	-	VC..1103..	T8	ST2508
SVVCN1616H11	16	16	100	8	16	-			
SVVCN2020K11	20	20	125	10	20	-			
SVVCN2525M11	25	25	150	12.5	25	-			
SVVCN1616H16	16	16	100	8	16	-	VC..1604..	T15	ST3509
SVVCN2020K16	20	20	125	10	20	-			
SVVCN2525M16	25	25	150	12.5	25	-			
SVVCN3232P16	32	32	170	16	32	-			

Insert

External Toolholder

Internal Toolholder

Threading

Parting, Grooving

Miniature Tool

Internal Toolholder
Multi-clamp Boring Bar

MCLNR/L



CN □□

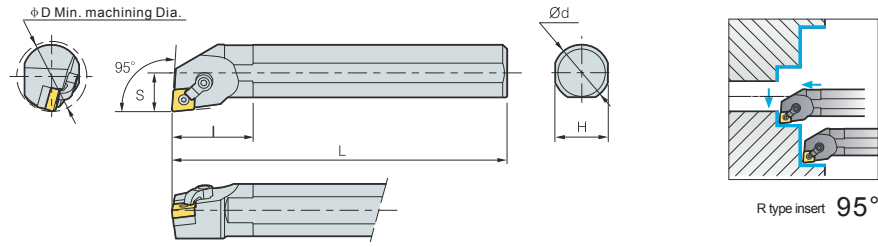

(mm)

Order No.	Dimension (mm)						Insert	Pin	Shim	Wrench	Screw	Clamp
	D	d	H	L	S	I						
S20R-MCLNR/L12	25	20	18	200	13	40	CN..1204..	MLP44-A	-	LH025 LH030	MS620	MC620
S25R-MCLNR/L12	30	25	23	200	15.5	40		MLP46-A	CMS432		MS625	
S32S-MCLNR/L12	40	32	30	250	19.5	48						

MDUNR/L



DN □□

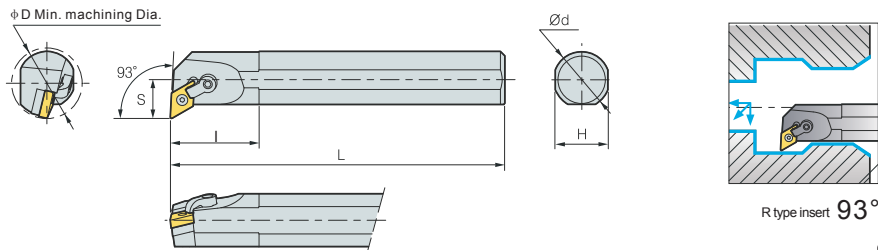

(mm)

Order No.	Dimension (mm)						Insert	Pin	Shim	Wrench	Screw	Clamp
	D	d	H	L	S	I						
S25R-MDUNR/L15	32	25	18	200	13	40	DN..1504..	MLP44-A	DMS432	LH025 LH030	MS620	MC620
S32S-MDUNR/L15	40	32	23	250	15.5	40		MLP46-A			MS625	

MSKNR/L



SN □□

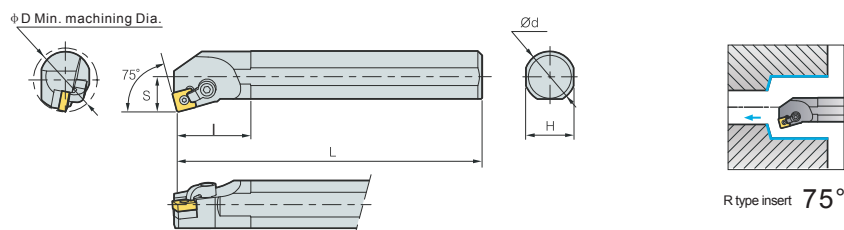

(mm)

Order No.	Dimension (mm)						Insert	Pin	Shim	Wrench	Screw	Clamp
	D	d	H	L	S	I						
S25R-MSKNR/L12	30	25	23	200	15	40	SN..1204..	MLP44-A	-	LH025LH	MS620	MC620
S40T-MSKNR/L12	50	40	37	300	25.5	55		MLP46-A	SMS432		-	

Insert

External Toolholder

Internal Toolholder

Threading

Parting, Grooving

Miniature Tool

Internal Toolholder
Multi-clamp Boring Bar

Insert

MTUNR/L



TN □□

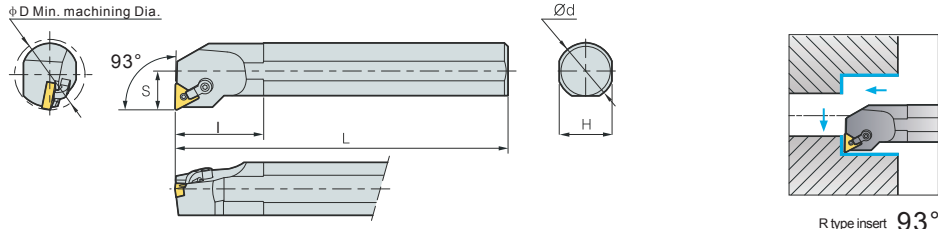

R type insert 93°

(mm)

Order No.	Dimension (mm)						Insert	Pin	Shim	Wrench	Screw	Clamp
	D	d	H	L	S	I						
S20R-MTUNR/L16	25	20	18	200	13	40	TN..1604..	MLP33L-A	-	LH020 LH025	MS520	MC515
S25R-MTUNR/L16	30	25	23	200	15.5	40		MLP34L-A	TMS322	LH020/030	MS625	MC620
S32S-MTUNR/L16	40	32	30	250	19.5	48						

External Toolholder

Internal Toolholder

Threading

MVUNR/L



VN □□

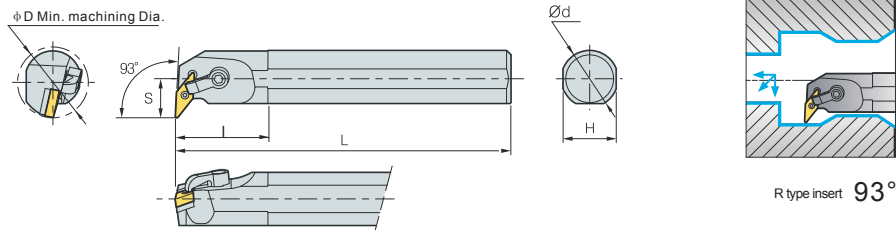

R type insert 93°

(mm)

Order No.	Dimension (mm)						Insert	Pin	Shim	Wrench	Screw	Clamp
	D	d	H	L	S	I						
S25R-MVUNR/L16	32	25	23	200	18	45	VN..1604..	MLP33L-A	-	LH020/025	MS520	MC515
S32S-MVUNR/L16	40	32	30	250	21	50		MLP34L-A	VMS322	LH020 LH025	MS625	MC620
S40T-MVUNR/L16	50	40	37	300	26	55						

Parting, Grooving

Miniature Tool

MWLNR/L



WN □□

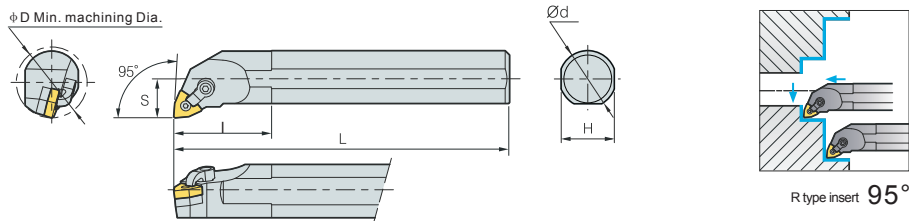

R type insert 95°

(mm)

Order No.	Dimension (mm)						Insert	Pin	Shim	Wrench	Screw	Clamp
	D	d	H	L	S	I						
S20R-MWLNR/L08	25	20	18	200	13	40	WN..0804..	MLP44-A	-	LH025	MS520	MC515
S25R-MWLNR/L08	30	25	23	200	15	40		MLP46-A	WMS432			
S32S-MWLNR/L08	40	32	30	250	20	48						

Internal Toolholder
Screw-on Clamp Toolholder

SCLCR/L



CC □□

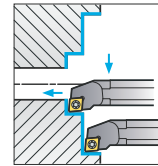
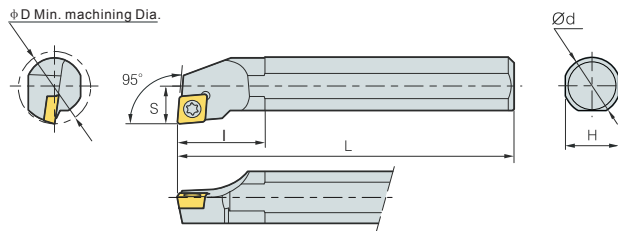

R type insert 95°

S:Steel Shank C:Carbide Shank

(mm)

Order No.	Dimension (mm)						Insert	Wrench	Screw
	D	d	H	L	S	I			
S08K-SCLCR/L06	10	8	7	125	5	20	CC..0602..	TRX08	BFTX2506
S10K-SCLCR/L06	12	10	9	125	6	22			
S12M-SCLCR/L06	16	12	11	150	8	26			
S16Q-SCLCR/L06	20	16	15	180	10	32			
S12M-SCLCR/L09	16	12	11	150	8	26	CC..09T3..	TRX15	BFTX4008
S14Q-SCLCR/L09	16	14	13	180	8	26			
S16Q-SCLCR/L09	20	16	15	180	10	32			
S20R-SCLCR/L09	25	20	18	200	13	40			
S25R-SCLCR/L09	30	25	23	200	15	40			
S32S-SCLCR/L09	38	32	30	250	20	48			
C08K-SCLCR/L06	10	8	7	125	5	20	CC..0602..	TRX08	BFTX2506
C10K-SCLCR/L06	12	10	9	125	6	22			
C12M-SCLCR/L06	16	12	11	150	8	26			
C12M-SCLCR/L09	16	12	11	150	8	26			
C16Q-SCLCR/L09	20	16	15	180	10	32	CC..09T3..	TRX15	BFTX4008

SDQCR/L



DC □□

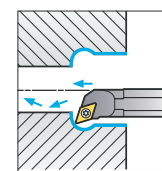
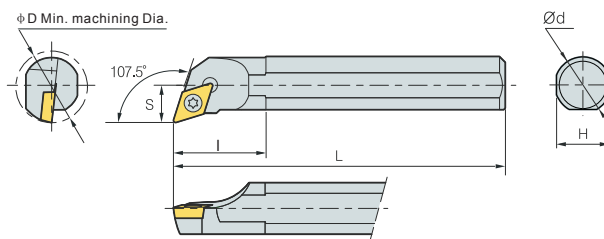

R type insert 107.5°

S:Steel Shank C:Carbide Shank

(mm)

Order No.	Dimension (mm)						Insert	Wrench	Screw
	D	d	H	L	S	I			
S10K-SDQCR/L07	13	10	9	125	6.5	22	DC..0702..	TRX08	BFTX2506
S12M-SDQCR/L07	16	12	11	150	8	30			
S16Q-SDQCR/L07	20	16	15	180	10.5	35			
S16Q-SDQCR/L11	20	16	15	180	10.5	35	DC..11T3..	TRX15	BFTX4008
S20R-SDQCR/L11	25	20	18	200	12.5	40			
S25R-SDQCR/L11	32	25	23	200	15.5	45			
S32S-SDQCR/L11	40	32	30	250	19.5	48			
C10M-SDQCR/L07	13	10	9	150	6.5	22	DC..0702..	TRX08	BFTX2506
C12Q-SDQCR/L07	16	12	11	180	8	30			
C16Q-SDQCR/L07	20	16	15	180	10.5	35			

Internal Toolholder
Screw-on Clamp Toolholder

SDUCR/L

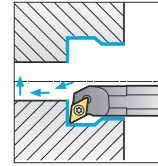
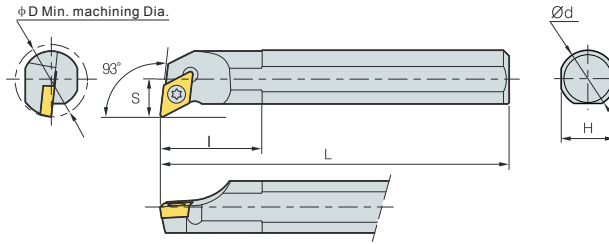

R type insert 93°

(mm)

S:Steel Shank C:Carbide Shank

Order No.	Dimension (mm)						Insert	Wrench	Screw
	D	d	H	L	S	I			
S10K-SDUCR/L07	13	10	9	125	7	25	DC..0702..	TRX08	BFTX2506
S12M-SDUCR/L07	16	12	11	150	8.5	30			
S16Q-SDUCR/L07	20	16	15	180	11	30			
S16Q-SDUCR/L11	20	16	15	180	11	30	DC..11T3..	TRX15	BFTX4008
S20R-SDUCR/L11	25	20	18	200	13	40			
S25R-SDUCR/L11	32	25	23	200	16	45			
S32S-SDUCR/L11	40	32	30	250	20	48	DC..0702..	TRX08	BFTX2506
C10M-SDUCR/L07	13	10	9	150	7	25			
C12Q-SDUCR/L07	16	12	11	180	8.5	30			
C16R-SDUCR/L11	20	16	15	200	11	30			

SDZCR/L

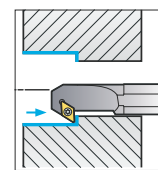
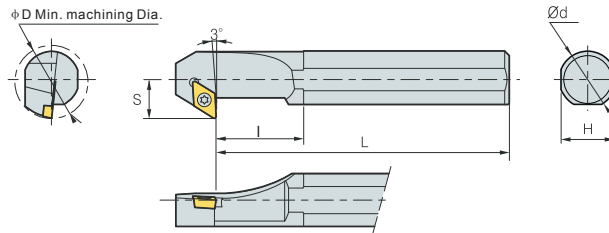

R type insert 93°

(mm)

Order No.	Dimension (mm)						Insert	Wrench	Screw
	D	d	H	L	S	I			
S10M-SDZCR/L07	14	10	9	150	8.5	18	DC .0702..	TRX08	BFTX2506
S12M-SDZCR/L07	17	12	11	150	10.5	20			
S16Q-SDZCR/L07	21	16	15	180	12.5	26			
S20R-SDZCR/L11	26	20	18	200	15.5	27	DC..11T3..	TRX15	BFTX4008
S25R-SDZCR/L11	33	25	23	200	18	32			
S32S-SDZCR/L11	40	32	30	250	21.5	42			

Internal Toolholder
Screw-on Clamp Toolholder

STUCR/L



TC □□

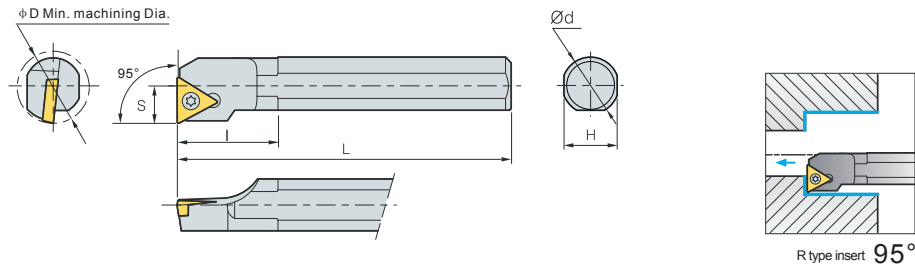

S:Steel Shank C:Carbide Shank

(mm)

Order No.	Dimension (mm)						Insert	Wrench	Screw
	D	d	H	L	S	I			
S08K-STUCR/L09	10	8	7	125	5.5	20	TC..0902..	TRX06	BFTX2204
S10K-STUCR/L09	12	10	9	125	6	22			
S12M-STUCR/L09	16	12	11	150	8	26			
S10K-STUCR/L11	12	10	9	125	6	22	TC..1102..	TRX08	BFTX2506
S12M-STUCR/L11	16	12	11	150	8	26			
S16Q-STUCR/L11	20	16	15	180	10	32			
S20R-STUCR/L11	25	20	18	200	13	40			
S25R-STUCR/L11	30	25	23	200	15	40	TC..16T3..	TRX15	BFTX4010
S20R-STUCR/L16	25	20	18	200	13	40			
S25S-STUCR/L16	30	25	23	250	15	40			
S32S-STUCR/L16	38	32	30	250	20	48			
S32T-STUCR/L16	38	32	30	300	20	48	TC..0902..	TRX06	BFTX2204
C08K-STUCR/L09	10	8	7	125	5.5	20			
C10K-STUCR/L09	12	10	9	125	6	22			
C10K-STUCR/L11	12	10	9	125	6	22	TC..1102..	TRX08	BFTX2506
C12M-STUCR/L11	16	12	11	150	8	26			
C16R-STUCR/L11	20	16	15	200	10	32			

Insert

External Toolholder

Internal Toolholder

Threading

Parting, Grooving

Miniature Tool

Internal Toolholder
Screw-on Clamp Toolholder

STUPR/L



TP □□

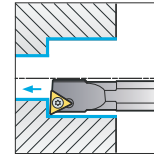
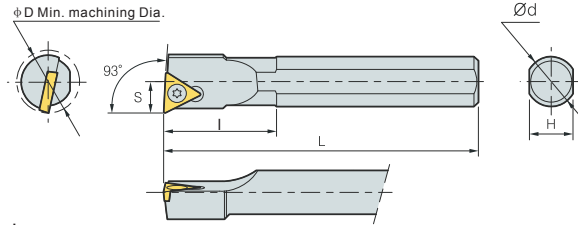

R type insert 93°

S:Steel Shank C:Carbide Shank

Order No.	Dimension (mm)						Insert	Wrench	Screw
	D	d	H	L	S	I			
S08K-STUPR/L08	10	8	7	125	5.5	20	TP..0802..	TRX06	BFTX2204
S10K-STUPR/L08	12	10	9	125	6	22			BFTX2206
S12M-STUPR/L08	16	12	11	150	8	26			
S08K-STUPR/L09	10	8	7	125	5.5	20	TP..0902..	TRX08	BFTX2506
S10K-STUPR/L09	12	10	9	125	6	22			
S12M-STUPR/L11	16	12	11	150	8	26			
S14Q-STUPR/L11	16	14	13	180	8	26	TP..1103..	TRX10	BFTX3008
S16Q-STUPR/L11	20	16	15	180	10	32			
S20R-STUPR/L11	25	20	18	200	13	40			
S25R-STUPR/L11	30	25	23	200	15	40			
C08K-STUPR/L08	10	8	7	125	5.5	20			
C08K-STUPR/L09	10	8	7	125	5.5	20	TP..0902..	TRX08	BFTX2506
C10K-STUPR/L09	12	10	9	125	6	22			
C10K-STUPR/L11	12	10	9	125	6	22			
C12M-STUPR/L11	16	12	11	150	8	26	TP..1103..	TRX10	BFTX3008
C16R-STUPR/L11	20	16	15	200	10	32			

STFCR/L



TC □□

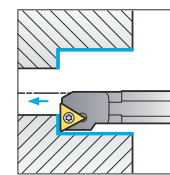
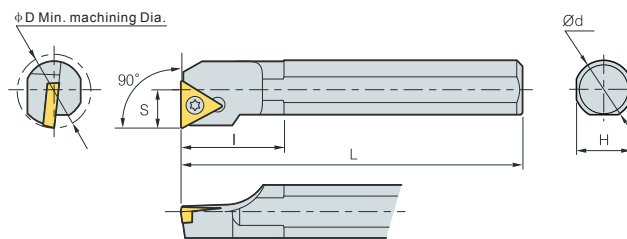

R type insert 90°

Order No.	Dimension (mm)						Insert	Wrench	Screw
	D	d	H	L	S	I			
S08K-STFCR/L09	10	8	7	125	5.5	20	TC..0902..	TRX06	BFTX2206
S10K-STFCR/L09	12	10	9	125	6	22			
S10K-STFCR/L11	12	10	9	125	6	22			
S12M-STFCR/L11	16	12	11	150	8	26	TC..1102..	TRX08	BFTX2506
S16Q-STFCR/L11	20	16	15	180	10	32			
S20R-STFCR/L16	25	20	18	200	13	36			
S25S-STFCR/L16	30	25	23	250	15	40			
S32S-STFCR/L16	38	32	30	250	20	48			
							TC..16T3..	TRX15	BFTX4010

Internal Toolholder
Screw-on Clamp Toolholder

SVQBR/L



VB □□

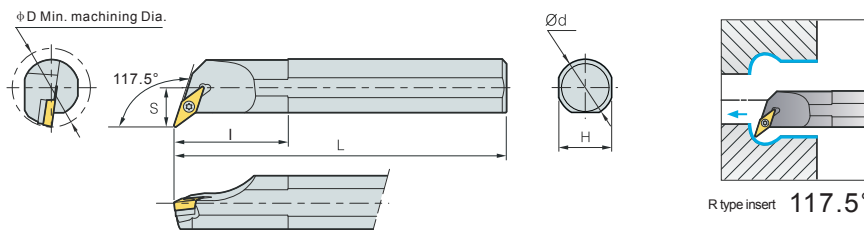

(mm)

Order No.	Dimension (mm)						Insert	Wrench	Screw	Shim	ShimScre
	D	d	H	L	S	I					
S12M-SVQBR/L11	16	12	11	150	9	28	VB..1103..	TRX08	BFTX2506	-	-
S16Q-SVQBR/L11	20	16	15	180	11	35					
S20R-SVQBR/L11	25	20	18	200	13	40	VB..1604..	TRX15	BFTX3508	-	-
S20R-SVQBR/L16	25	20	18	200	13	40					
S25S-SVQBR/L16	32	25	23	250	16	45					
S32S-SVQBR/L16	40	32	30	250	20	48					
S40T-SVQBR/L16	50	40	37	300	25.5	60		TRX15 LH035	BFTX3512	VSS322	BX0535

SVUBR/L



VB □□

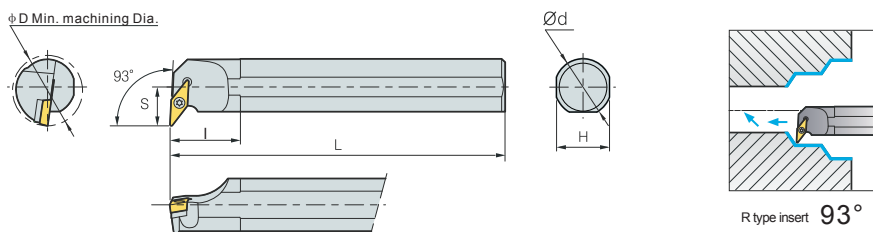

(mm)

Order No.	Dimension (mm)						Insert	Wrench	Screw	Shim	ShimScre
	D	d	H	L	S	I					
S16Q-SVUBR/L11	22	16	15	180	13	30	VB..1103..	TRX08	BFTX2506	-	-
S20R-SVUBR/L11	27	20	18	200	15	40					
S25S-SVUBR/L16	32	25	23	250	18	45	VB..1604..	TRX15	BFTX3508	-	-
S32S-SVUBR/L16	40	32	30	250	22	50					
S40T-SVUBR/L16	50	40	37	300	27	55					

SVQCR/L



VC □□

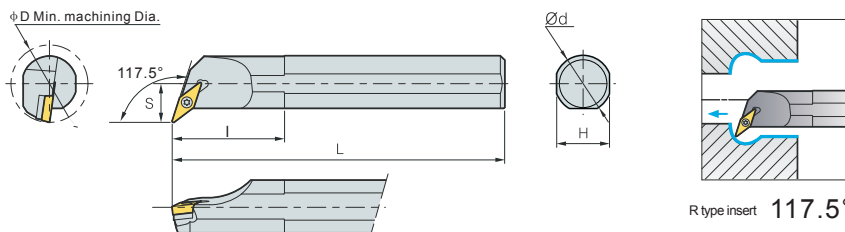

(mm)

Order No.	Dimension (mm)						Insert	Wrench	Screw	Shim	ShimScre
	D	d	H	L	S	I					
S12M-SVQCR/L11	16	12	11	150	9	28	VC..1103..	TRX08	BFTX2506	-	-
S16Q-SVQCR/L11	20	16	15	180	11	35					
S20R-SVQCR/L11	25	20	18	200	13	40	VC..1604..	TRX15	BFTX3508	-	-
S20R-SVQCR/L16	25	20	18	200	13	40					
S25S-SVQCR/L16	32	25	23	250	16	45					
S32S-SVQCR/L16	40	32	30	250	20	48					
S40T-SVQCR/L16	50	40	37	300	25.5	60		TRX15 LH035	BFTX3512	VSS322	BX0535

Internal Toolholder
Screw-on Clamp Toolholder

SVUCR/L



VC □□

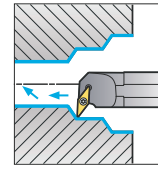
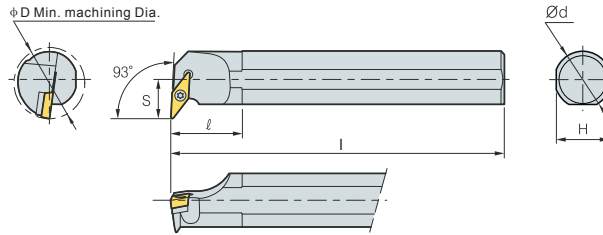

R type insert 93°

(mm)

Order No.	Dimension (mm)						Insert	Wrench	Screw	Shim	ShimScre
	D	d	H	L	S	l					
S16Q-SVUCR/L11	22	16	15	180	13	30	VC..1103..			-	-
S20R-SVUCR/L11	27	20	18	200	15	40					
S25S-SVUCR/L16	32	25	23	250	18	45	VC..1604..			-	-
S32S-SVUCR/L16	40	32	30	250	22	50					
S40T-SVUCR/L16	50	40	37	300	27	55					

Insert
 External Toolholder
 Internal Toolholder
 Threading
 Parting, Grooving
 Miniature Tool

Internal Toolholder Steel Boring Bar with Coolant Hole

MCLNR/L



CN □□

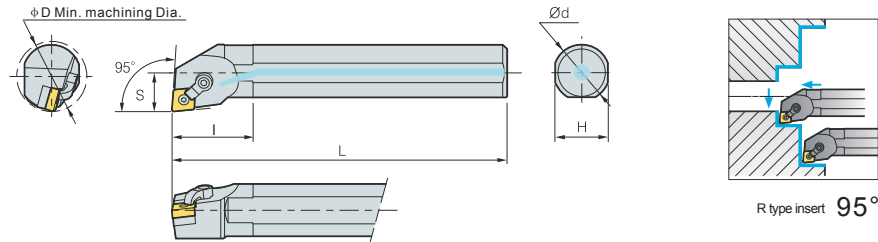

(mm)

Order No.	Dimension (mm)						Insert	Pin	Shim	Wrench	Screw	Clamp
	D	d	H	L	S	I						
A20R-MCLNR/L12	25	20	18	200	13	40	CN..1204..	MLP44-A	-	LH025 LH030	MS620	MC620
A25R-MCLNR/L12	30	25	23	200	15.5	40		MLP46-A	CMS432		MS625	
A32S-MCLNR/L12	40	32	30	250	19.5	48						

MDUNR/L



DN □□

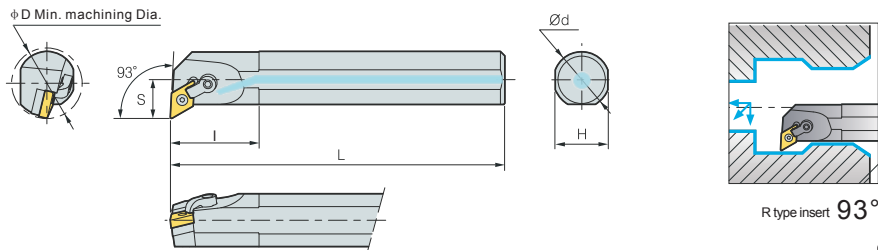

(mm)

Order No.	Dimension (mm)						Insert	Pin	Shim	Wrench	Screw	Clamp
	D	d	H	L	S	I						
A25R-MDUNR/L15	32	25	18	200	13	40	DN..1504..	MLP44-A	DMS432	LH025 LH030	MS620	MC620
A32S-MDUNR/L15	40	32	23	250	15.5	40		MLP46-A				

MTUNR/L



TN □□

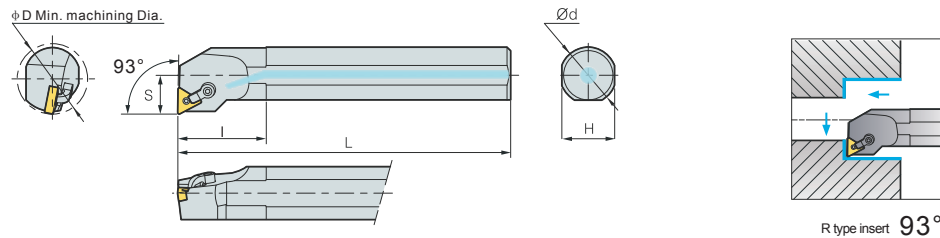

(mm)

Order No.	Dimension (mm)						Insert	Pin	Shim	Wrench	Screw	Clamp
	D	d	H	L	S	I						
A20R-MTUNR/L16	25	20	18	200	13	40	TN..1604..	MLP33L-A	-	LH020 LH025	MS520	MC515
A25R-MTUNR/L16	30	25	23	200	15.5	40		MLP34L-A	TMS322		LH020/030	
A32S-MTUNR/L16	40	32	30	250	19.5	48						

Internal Toolholder Steel Boring Bar with Coolant Hole

MVUNR/L



VN □□

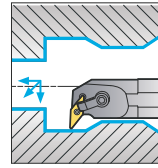
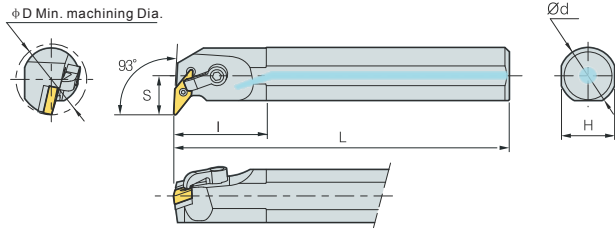

R type insert 93°

(mm)

Order No.	Dimension (mm)						Insert	Pin	Shim	Wrench	Screw	Clamp
	D	d	H	L	S	I						
A25R-MVUNR/L16	32	25	23	200	18	45	VN..1604..	MLP33L-A	-	LH020/025	MS520	MC515
A32S-MVUNR/L16	40	32	30	250	21	50		MLP34L-A	VMS322	LH020 LH025	MS625	MC620
A40T-MVUNR/L16	50	40	37	300	26	55						

MWLNR/L



WN □□

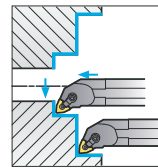
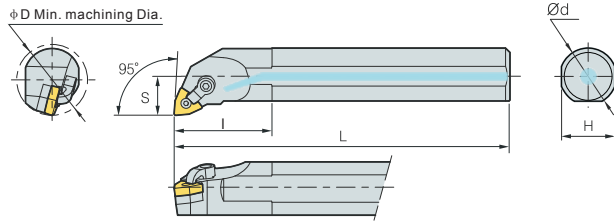

R type insert 95°

(mm)

Order No.	Dimension (mm)						Insert	Pin	Shim	Wrench	Screw	Clamp
	D	d	H	L	S	I						
A20R-MWLNR/L08	25	20	18	200	13	40	WN..0804..	MLP44-A	-	LH025	MS520	MC515
A25R-MWLNR/L08	30	25	23	200	15	40						
A32S-MWLNR/L08	40	32	30	250	20	48		MLP46-A	WMS432			

Internal Toolholder

Steel Boring Bar with Coolant Hole

SCLCR/L



CC □□

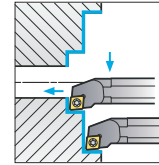
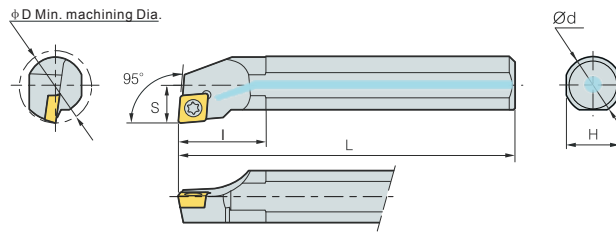

R type insert 95°

(mm)

Order No.	Dimension (mm)						Insert	Wrench	Screw
	D	d	H	L	S	I			
A08K-SCLCR/L06	10	8	7	125	5	20	CC..0602..	TRX08	BFTX2506
A10K-SCLCR/L06	12	10	9	125	6	22			
A12M-SCLCR/L06	16	12	11	150	8	26			
A16Q-SCLCR/L06	20	16	15	180	10	32			
A12M-SCLCR/L09	16	12	11	150	8	26	CC..09T3..	TRX15	BFTX4008
A16Q-SCLCR/L09	20	16	15	180	10	32			
A20R-SCLCR/L09	25	20	18	200	13	40			
A25R-SCLCR/L09	30	25	23	200	15	40			

SDQCR/L



DC □□

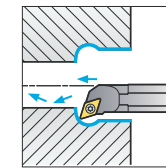
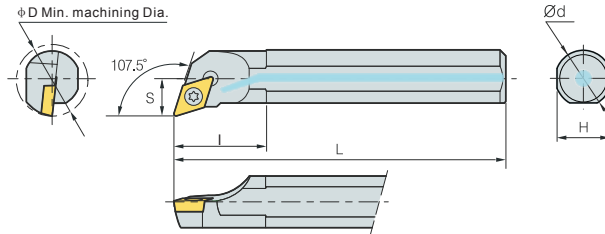

R type insert 107.5°

(mm)

Order No.	Dimension (mm)						Insert	Wrench	Screw
	D	d	H	L	S	I			
A10K-SDQCR/L07	13	10	9	125	6.5	22	DC..0702..	TRX08	BFTX2506
A12M-SDQCR/L07	16	12	11	150	8	30			
A16Q-SDQCR/L07	20	16	15	180	10.5	35			
A16Q-SDQCR/L11	20	16	15	180	10.5	35	DC..11T3..	TRX15	BFTX4008
A20R-SDQCR/L11	25	20	18	200	12.5	40			
A25R-SDQCR/L11	32	25	23	200	15.5	45			
A32S-SDQCR/L11	40	32	30	250	19.5	48			

Internal Toolholder

Steel Boring Bar with Coolant Hole

SDUCR/L



DC □□

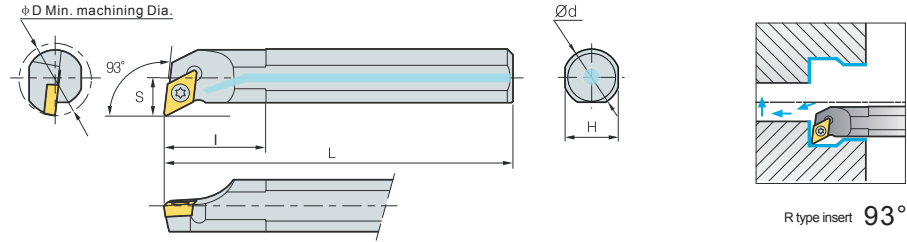

(mm)

Order No.	Dimension (mm)						Insert	Wrench	Screw
	D	d	H	L	S	I			
A10K-SDUCR/L07	13	10	9	125	7	25	DC..0702..	TRX08	BFTX2506
A12M-SDUCR/L07	16	12	11	150	8.5	30			
A16Q-SDUCR/L07	20	16	15	180	11	30			
A16Q-SDUCR/L11	20	16	15	180	11	30	DC..11T3..	TRX15	BFTX4008
A20R-SDUCR/L11	25	20	18	200	13	40			
A25R-SDUCR/L11	32	25	23	200	16	45			
A32S-SDUCR/L11	40	32	30	250	20	48			

SDZCR/L



DC □□

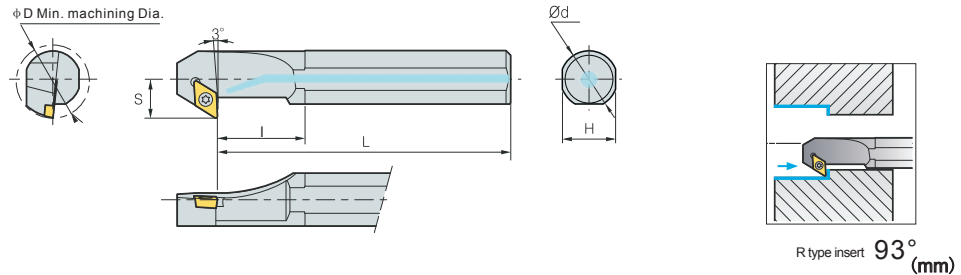

R type insert 93° (mm)

Order No.	Dimension (mm)						Insert	Wrench	Screw
	D	d	H	L	S	I			
A10M-SDZCR/L07	14	10	9	150	8.5	18	DC..0702..	TRX08	BFTX2506
A12M-SDZCR/L07	17	12	11	150	10.5	20			
A16Q-SDZCR/L07	21	16	15	180	12.5	26			
A20R-SDZCR/L11	26	20	18	200	15.5	27	DC..11T3..	TRX15	BFTX4008
A25R-SDZCR/L11	33	25	23	200	18	32			
A32S-SDZCR/L11	40	32	30	250	21.5	42			

Internal Toolholder

Steel Boring Bar with Coolant Hole

STUCR/L

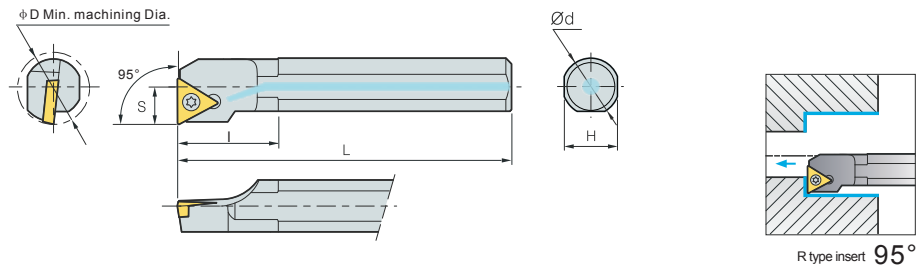

(mm)

Order No.	Dimension (mm)						Insert	Wrench	Screw
	D	d	H	L	S	I			
A08K-STUCR/L09	10	8	7	125	5.5	20	TC..0902..	TRX06	BFTX2204
A10K-STUCR/L09	12	10	9	125	6	22			
A10K-STUCR/L11	12	10	9	125	6	22	TC..1102..	TRX08	BFTX2506
A12M-STUCR/L11	16	12	11	150	8	26			
A16Q-STUCR/L11	20	16	15	180	10	32	TC..16T3..	TRX15	BFTX4010
A20R-STUCR/L16	25	20	18	200	13	40			
A25S-STUCR/L16	30	25	23	250	15	40			
A32S-STUCR/L16	38	32	30	250	20	48			
A32T-STUCR/L16	38	32	30	300	20	48			

STUPR/L

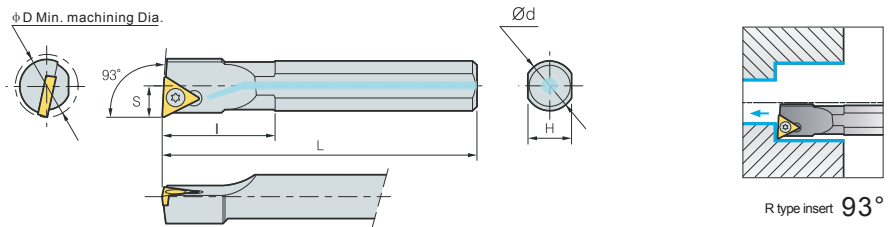

(mm)

Order No.	Dimension (mm)						Insert	Wrench	Screw
	D	d	H	L	S	I			
A08K-STUPR/L08	10	8	7	125	5.5	20	TP..0802..	TRX06	BFTX2204
A10K-STUPR/L08	12	10	9	125	6	22			BFTX2206
A08K-STUPR/L09	10	8	7	125	5.5	20	TP..0902..	TRX08	BFTX2506
A10K-STUPR/L09	12	10	9	125	6	22			
A10K-STUPR/L11	12	10	9	125	6	22	TP..1103..	TRX10	BFTX3008
A12M-STUPR/L11	16	12	11	150	8	26			
A16Q-STUPR/L11	20	16	15	180	10	32			
A20R-STUPR/L11	25	20	18	200	13	40			
A25R-STUPR/L11	30	25	23	200	15	40			

Internal Toolholder

Steel Boring Bar with Coolant Hole

STFCR/L



TC □□

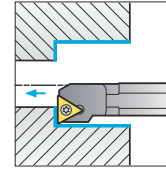
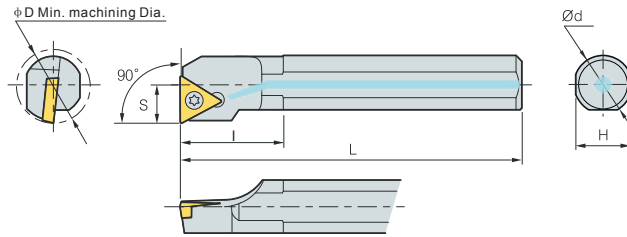

R type insert 90°

(mm)

Order No.	Dimension (mm)						Insert	Wrench	Screw
	D	d	H	L	S	I			
A08K-STFCR/L09	10	8	7	125	5.5	20	TC..0902..	TRX06	BFTX2206
A10K-STFCR/L09	12	10	9	125	6	22			
A10K-STFCR/L11	12	10	9	125	6	22	TC..1102..	TRX08	BFTX2506
A12M-STFCR/L11	16	12	11	150	8	26			
A16Q-STFCR/L11	20	16	15	180	10	32	TC..16T3..	TRX15	BFTX4010
A20R-STFCR/L16	25	20	18	200	13	36			
A25S-STFCR/L16	30	25	23	250	15	40			
A32S-STFCR/L16	38	32	30	250	20	48			

SVQBR/L



VB □□

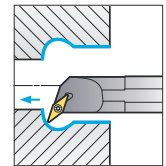
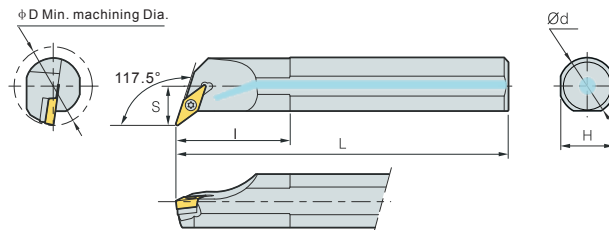

R type insert 117.5°

(mm)

Order No.	Dimension (mm)						Insert	Wrench	Screw	Shim	ShimScrew
	D	d	H	L	S	I					
A16Q-SVQBR/L11	20	16	15	180	11	35	VB..1103..	TRX08	BFTX2506	-	-
A20R-SVQBR/L11	25	20	18	200	13	40					
A20R-SVQBR/L16	25	20	18	200	13	40	VB..1604..	TRX15	BFTX3508	-	-
A25S-SVQBR/L16	32	25	23	250	16	45		TRX15 LH035	BFTX3512	VSS322	BX0535
A32S-SVQBR/L16	40	32	30	250	20	48					

Internal Toolholder

Steel Boring Bar with Coolant Hole

SVUBR/L



VB □□

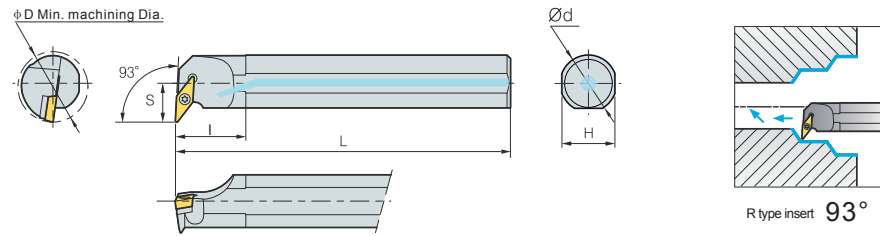

Order No.	Dimension (mm)						Insert	Wrench	Screw	Shim	ShimScrew
	D	d	H	L	S	I					
A16Q-SVUBR/L11	22	16	15	180	13	30	VB..1103..	TRX08	BFTX2506	-	-
A20R-SVUBR/L11	27	20	18	200	15	40					
A25S-SVUBR/L16	32	25	23	250	18	45					

SVQCR/L



VC □□

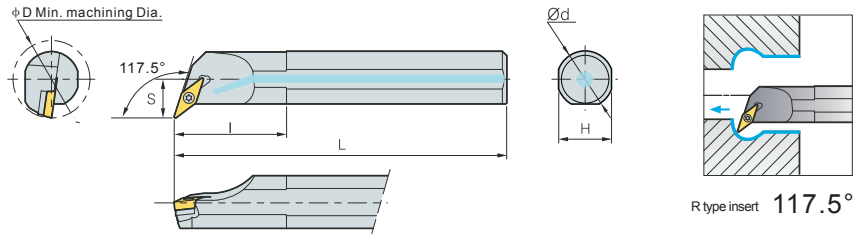

Order No.	Dimension (mm)						Insert	Wrench	Screw	Shim	ShimScrew
	D	d	H	L	S	I					
A12M-SVQCR/L11	16	12	11	150	9	28	VC..1103..	TRX08	BFTX2506	-	-
A16Q-SVQCR/L11	20	16	15	180	11	35					
A20R-SVQCR/L11	25	20	18	200	13	40					
A20R-SVQCR/L16	25	20	18	200	13	40	VC..1604..	TRX15	BFTX3508	-	-
A25S-SVQCR/L16	32	25	23	250	16	45					
A32S-SVQCR/L16	40	32	30	250	20	48					
A40T-SVQCR/L16	50	40	37	300	25.5	60		TRX15 LH035	BFTX3512	VSS322	BX0535

SVUCR/L



VC □□

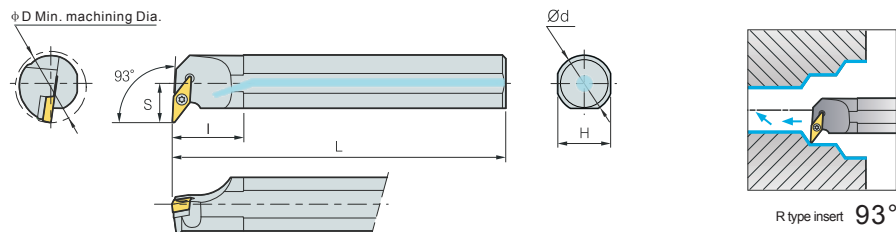

Order No.	Dimension (mm)						Insert	Wrench	Screw	Shim	ShimScrew
	D	d	H	L	S	I					
A16Q-SVUCR/L11	22	16	15	180	13	30	VC..1103..	TRX08	BFTX2506	-	-
A20R-SVUCR/L11	27	20	18	200	15	40					
A25S-SVUCR/L16	32	25	23	250	18	45					
A32S-SVUCR/L16	40	32	30	250	22	50	VC..1604..	TRX15 LH035	BFTX3512	VSS322	BX5035

Threading
Thread Inserts

Partial profile
60° thread angle

Grade: TG3225

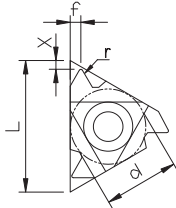
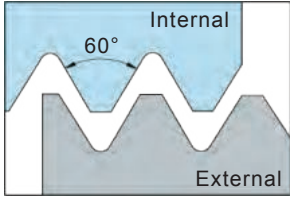
						(mm)	
Type	Order No.	Pitch	Dimension (mm)				
			L	X	f	r	d
External	16ERA60-TC	0.5-1.5	16	0.8	0.9	0.08	9.525
	16ERAG60-TC	0.5-3.0	16	1.1	1.5	0.08	9.525
	16ERG60-TC	1.75-3.0	16	1.2	1.7	0.25	9.525
	22ERN60-TC	3.5-5.0	22	1.7	2.5	0.51	12.7
Internal	11IRA60-TC	0.5-1.5	11	0.8	0.9	0.08	6.35
	16IRA60-TC	0.5-1.5	16	0.8	0.9	0.08	9.525
	16IRAG60-TC	0.5-3.0	16	1.1	1.5	0.08	9.525
	16IRG60-TC	1.75-3.0	16	1.2	1.7	0.13	9.525
	22IRN60-TC	3.5-5.0	22	1.7	2.5	0.25	12.7

Partial profile
55° thread angle

Grade: TG3225

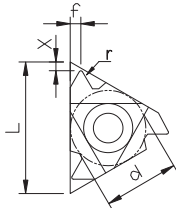
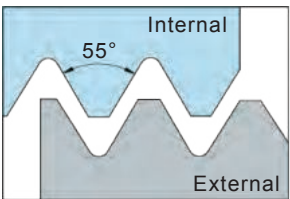
						(mm)	
Type	Order No.	Pitch	Dimension (mm)				
			L	X	f	r	d
External	16ERA55-TC	48-16	16	0.8	0.9	0.08	9.525
	16ERAG55-TC	48-8	16	1.1	1.5	0.08	9.525
	16ERG55-TC	14-8	16	1.2	1.7	0.21	9.525
	22ERN55-TC	7-5	22	1.7	2.5	0.44	12.7
Internal	11IRA55-TC	48-16	11	0.8	0.9	0.08	6.35
	16IRA55-TC	48-16	16	0.8	0.9	0.08	9.525
	16IRAG55-TC	48-8	16	1.1	1.5	0.08	9.525
	16IRG55-TC	14-8	16	1.2	1.7	0.21	9.525
	22IRN55-TC	7-5	22	1.7	2.5	0.44	12.7

Threading
Thread Inserts

Full profile
ISO Metric

Grade: TG3225

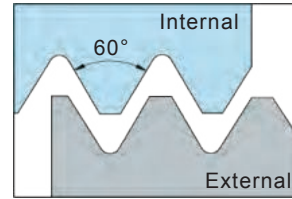
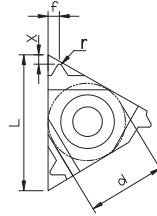

(mm)

Type	Order No.	Pitch	Dimension (mm)				
			L	X	f	r	d
External	16ER1.00ISO-TC	1	16	0.8	0.7	0.14	9.525
	16ER1.25ISO-TC	1.25	16	0.8	0.9	0.18	9.525
	16ER1.50ISO-TC	1.5	16	0.8	1	0.22	9.525
	16ER1.75ISO-TC	1.75	16	1.2	1.2	0.25	9.525
	16ER2.00ISO-TC	2	16	1.2	1.3	0.29	9.525
	16ER2.50ISO-TC	2.5	16	1.2	1.5	0.36	9.525
	16ER3.00ISO-TC	3	16	1.2	1.5	0.43	9.525
	22ER3.50ISO-TC	3.5	22	1.6	2.3	0.45	12.7
	22ER4.00ISO-TC	4	22	1.6	2.3	0.52	12.7
	22ER4.50ISO-TC	4.5	22	1.7	2.4	0.58	12.7
	22ER5.00ISO-TC	5	22	1.7	2.5	0.63	12.7
Internal	11IR1.00ISO-TC	1	11	0.8	0.7	0.07	6.35
	11IR1.25ISO-TC	1.25	11	0.8	0.9	0.09	6.35
	11IR1.50ISO-TC	1.5	11	0.8	1	0.11	6.35
	11IR1.75ISO-TC	1.75	11	0.9	1.1	0.13	6.35
	11IR2.00ISO-TC	2	11	0.9	1.1	0.15	6.35
	16IR1.00ISO-TC	1	16	0.8	0.7	0.07	9.525
	16IR1.25ISO-TC	1.25	16	0.8	0.9	0.09	9.525
	16IR1.50ISO-TC	1.5	16	0.8	1	0.11	9.525
	16IR1.75ISO-TC	1.75	16	1.2	1.2	0.13	9.525
	16IR2.00ISO-TC	2	16	1.2	1.3	0.15	9.525
	16IR2.50ISO-TC	2.5	16	1.2	1.5	0.18	9.525
	16IR3.00ISO-TC	3	16	1.2	1.5	0.22	9.525
	22IR3.50ISO-TC	3.5	22	1.6	2.3	0.22	12.7
	22IR4.00ISO-TC	4	22	1.6	2.3	0.25	12.7
	22IR4.50ISO-TC	4.5	22	1.6	2.4	0.28	12.7
	22IR5.00ISO-TC	5	22	1.6	2.3	0.32	12.7

Insert

External Toolholder

Internal Toolholder

Threading

Parting, Grooving

Miniature Tool

Threading
Thread Inserts

Full profile
Unified

Grade: TG3225

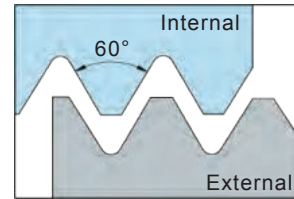
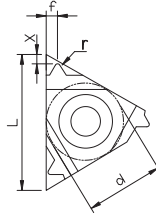

(mm)

Type	Order No.	Pitch	Dimension (mm)				
			L	X	f	r	d
External	16ER24UN-TC	24	16	0.8	0.8	0.15	9.525
	16ER20UN-TC	20	16	0.8	0.9	0.18	9.525
	16ER18UN-TC	18	16	0.8	1	0.2	9.525
	16ER16UN-TC	16	16	0.9	1.1	0.23	9.525
	16ER14UN-TC	14	16	1.2	1.5	0.26	9.525
	16ER12UN-TC	12	16	1.2	1.5	0.31	9.525
	16ER10UN-TC	10	16	1.2	1.5	0.37	9.525
	16ER8UN-TC	8	16	1.3	1.7	0.46	9.525
Internal	11IR20UN-TC	20	11	0.8	0.9	0.09	6.35
	11IR18UN-TC	18	11	0.8	1	0.1	6.35
	16IR24UN-TC	24	16	0.8	0.8	0.08	9.525
	16IR20UN-TC	20	16	0.8	0.9	0.09	9.525
	16IR18UN-TC	18	16	0.8	1	0.1	9.525
	16IR16UN-TC	16	16	0.9	1.1	0.12	9.525
	16IR14UN-TC	14	16	1.2	1.5	0.13	9.525
	16IR12UN-TC	12	16	1.2	1.5	0.16	9.525
	16IR10UN-TC	10	16	1.2	1.5	0.19	9.525
	16IR8UN-TC	8	16	1.3	1.7	0.23	9.525

Threading
Thread Inserts

**Full profile
Whitworth**

Grade: TG3225

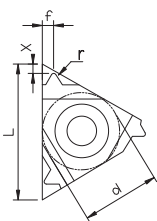
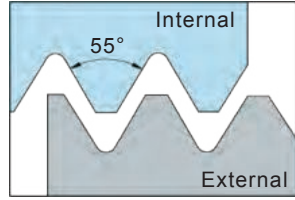
				 				(mm)
Type	Order No.	Pitch	Dimension (mm)					
			L	X	f	r	d	
External	16ER19W-TC	19	16	0.8	1	0.17	9.525	
	16ER14W-TC	14	16	1.2	1.5	0.24	9.525	
	16ER11W-TC	11	16	1.2	1.5	0.3	9.525	
Internal	16IR19W-TC	19	16	0.8	1	0.17	9.525	
	16IR14W-TC	14	16	1.2	1.5	0.24	9.525	
	16IR11W-TC	11	16	1.2	1.5	0.3	9.525	

Standard Cutting Conditions

ISO	Workpiece Material		Vc(m/min)
P	Non-Alloy steel	<0.25%C	120-230
		0.25%C- 0.55%C	100-195
		≥0.55%C	90-180
	Low Alloy Steel		60-180
	High Alloy Steel		70-140
M	Martensitic Stainless Steel		70-170
	Austenitic Stainless Steel		90-140
K	Grey Cast Iron		80-160
	Ductile Cast Iron		80-160
N	Cast Aluminum Alloy		100-500
	Aluminum Alloy		300-700
	Copper Alloy		80-300
S	Heat-resistance Alloy		10-50
	Titanium Alloy		50-70
H	Hardened Alloy	45-50 HRC	40-50
		51-55 HRC	30-50

Insert
External Toolholder
Internal Toolholder
Threading
Parting, Grooving
Miniature Tool

Threading
Thread Toolholder

External Threading Toolholders

SER
(Screw on system)

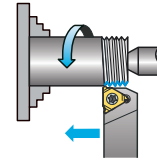
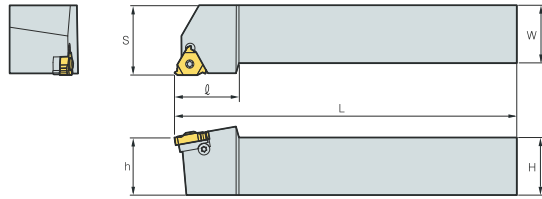

Righthand drawing
(mm)

Order No.	Dimension (mm)					Insert	Pin	Shim	Wrench	Screw
	H	W	S	L	h					
SER-1212H16	12	12	16	100	12	16ER..	ST3509	-	T15	-
SER-1616H16	16	16	20	100	16		ST3512	STM16	T15 L2.5	ST3006N
SER-2020K16	20	20	25	125	20					
SER-2525M16	25	25	32	150	25					
SER-3232P16	32	32	40	170	32					
SER-2525M22	25	25	32	150	25	22ER..	ST4016	STM22	T20 L3	ST4006N
SER-3232P22	32	32	40	170	32					

Internal Threading Bars

SNR
(Screw on system)

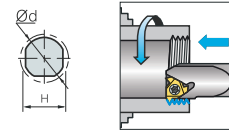
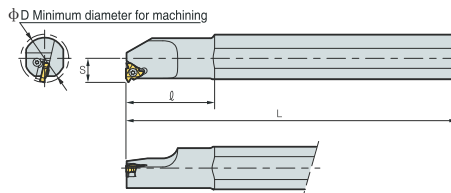

Righthand drawing

(mm)

Order No.	Dimension (mm)						Insert	Pin	Shim	Wrench	Screw
	D	d	L	S	H	I					
SNR-0008K11	11	8	125	5.5	7	20	11IR..	ST2508	-	T8	-
SNR-0010K11	13	10	125	6.5	9	22					
SNR-0012K11	15	12	125	7.5	11	26					
SNR-0016Q16	19	16	180	10	15	36	16IR..	ST3509	-	T15	-
SNR-0020R16	24	20	200	12	18	40					
SNR-0025R16	29	25	200	14.5	23	45					
SNR-0032T16	36	32	300	18.5	30	45					
SNR-0040T16	44	40	300	22	37	60					
SNR-0020R22	23	20	200	11.5	18	40	22IR..	ST4016	STM22	T20 L3	ST4006N
SNR-0025S22	31	25	250	16	23	45					
SNR-0032T22	38	32	300	19.5	30	45					
SNR-0040T22	46	40	300	24	37	60					

API tubing and casing round threading > Standard triangle series round threading inserts

Grade	Introduce of use performance and application
0124	With good red-hardness and toughness, suitable for the high-effective threading machine tooling the dry steel, intermediate grade and high-grade steel (such as J55, K55, N80, L80 etc.) tubing, casing treading and connecting threading.
0326	With good high-intensity and red-hardness, meanwhile own excellent impact resistance. Suitable for the high-effective threading machine tooling the intermediate and high grade steel (such as N80, P110. etc.) tubing, casing and connecting threading.

External threading insert

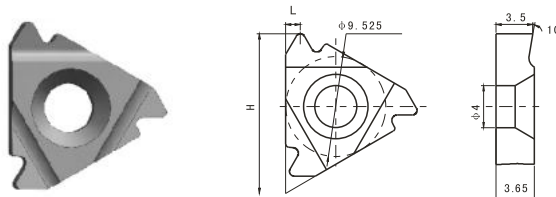

Ordering code	Teeth/inch	Taper	Thread form	H	L	Grade
16ER8API	8	1:16	API round tubing casing thread	15.2	1.4	0124/0326
16ER10API	10	1:16	API round tubing casing thread	15.2	1.2	0124/0326

Internal threading insert

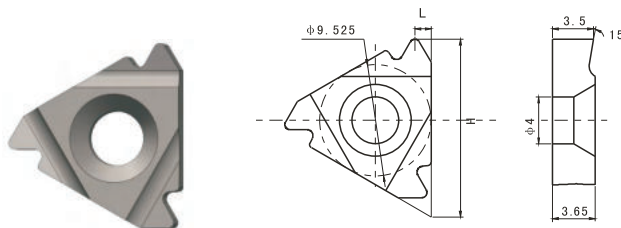

Ordering code	Teeth/inch	Taper	Thread form	H	L	Grade
16IR8API	8	1:16	API round tubing casing thread	15.2	1.4	0124/0326
16IR10API	10	1:16	API round tubing casing thread	15.2	1.2	0124/0326

Threading
Thread Inserts for Oil Pipe

API tubing and casing round threading > Papilionaceous series round threading inserts
 External threading insert

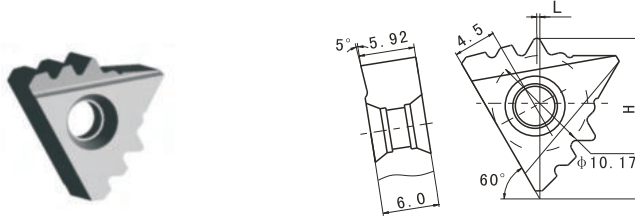

Ordering code	Teeth/inch	Taper	Thread form	H	L	Grade
B8W2-3(15°)	8	1:16	API round tubing thread	17.09	0.32	0124/0326
B8W2-3(12°)	8	1:16	API round casing thread	17.09	0.32	0124/0326
B10W2-4	10	1:16	API round tubing thread	17.09	0.32	0124/0326

Internal threading insert

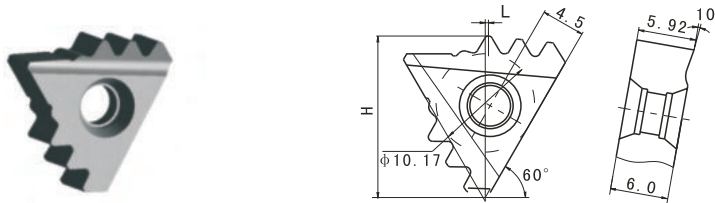

Ordering code	Teeth/inch	Taper	Thread form	H	L	Grade
B8N2-3	8	1:16	API round tubing casing thread	17.09	0.32	0124/0326
B10N2-4	10	1:16	API round tubing thread	17.09	0.01	0124/0326

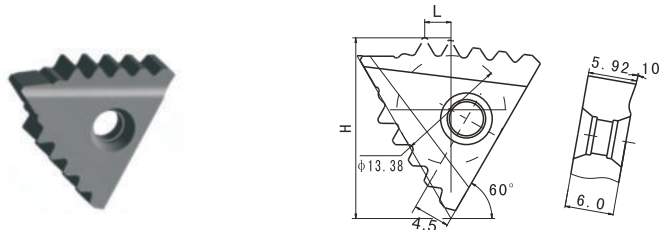

Ordering code	Teeth/inch	Taper	Thread form	H	L	Grade
B8N2-5	8	1:16	API round tubing casing thread	21.84	3.24	0124/0326

GOST buttress threading inserts for oil pipe
External threading insert

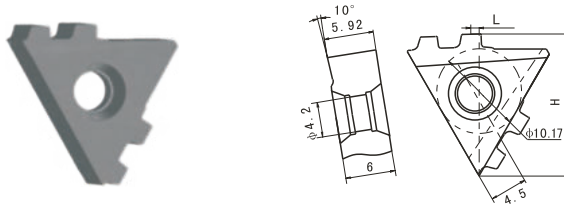

Ordering code	Teeth/inch	Taper	Thread form	H	L	Grade
E5BW2-2	5	1:16	OTTM \ OTTG	17.03	0.83	0124/0326

GOST buttress threading inserts for oil pipe

Internal threading insert

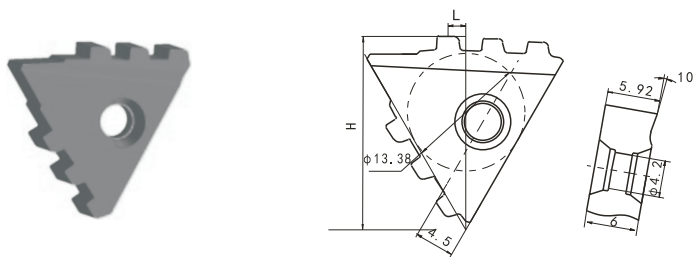

Ordering code	Teeth/inch	Taper	Thread form	H	L	Grade
E5BN2-3	5	1:16	OTTM \ OTTG	22.075	2.0	0124/0326

Threading
Thread Toolholder for Oil Pipe

Tool shank for papilionaceous round external threading inserts

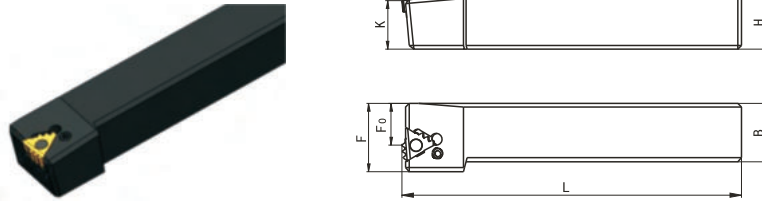

Type	Ordering code	Working range	Dimension							Machine tool
			L	H	K	B	F	F ₀	λ	
A	P10 (8) W2-A28×25	2 $\frac{3}{8}$ "~3 $\frac{1}{2}$ "	175	28	25	30	35	22	70'	C620
	P10 (8) W2-A35×32		175	35	32	35	40	27	70'	
	P10 (8) W2-A40×40		175	40	40	40	45	30	70'	
B	P10 (8) W2-B35×32	4"~5 $\frac{1}{2}$ "	175	35	32	35	40	27	50'	QK1312 Q1319
	P10 (8) W2-B40×40		175	40	40	40	45	30	50'	
C	P10 (8) W2-C35×32	6 $\frac{5}{8}$ "~8 $\frac{5}{8}$ "	175	35	32	35	40	27	30'	S1-344 S1-189
	P10 (8) W2-C40×40		175	40	40	40	45	30	30'	
D	P10 (8) W2-D35×32	9 $\frac{5}{8}$ "~13 $\frac{3}{8}$ "	175	35	32	35	40	27	15'	
	P10 (8) W2-D40×40		175	40	40	40	45	30	15'	

Accessory	Insert	Shim	Oblique rod	Lock screw	Wrench
Image					
Ordering code	B8W2-3H B10W2-4H	169. 798	φ4 Oblique rod	M6	S3

Threading
Thread Toolholder for Oil Pipe

Square tool shank for papilionaceous round internal threading inserts

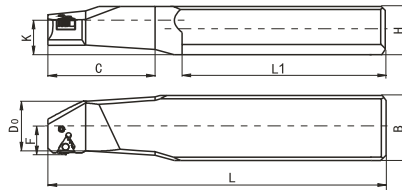

Type	Ordering code	Working range	Dimension									Machine tool
			L	L ₁	H	C	K	F	D ₀	B	λ	
A	P10 (8) N2-AS40×25	2 $\frac{3}{8}$ "~3 $\frac{1}{2}$ "	275	150	40	100	25	26	42	65	70'	C620
	P10 (8) N2-AS48×32		305	180	48	100	32	26	42	74	70'	QK1312 Q1319
	P10 (8) N2-AS48×32(A1)	2 $\frac{3}{8}$ "	265	140	48	85	32	26.5	45	74	70'	-
	P10 (8) N2-AS48×32(A2)	2 $\frac{7}{8}$ "~3 $\frac{1}{2}$ "	275	140	48	95	32	30.5	50	74	70'	-
B	P10 (8) N2-BS48×32	4"~5 $\frac{1}{2}$ "	335	180	48	130	32	31	50	74	50'	QK1312 Q1319
	P10 (8) N2-BS55×36		335	200	55	130	36	31	50	77	50'	S1-262 S1-245 QK1312 Q1319
C	P10 (8) N2-CS48×32	6 $\frac{5}{8}$ "~8 $\frac{5}{8}$ "	358	180	48	158	32	36	56	74	30'	S1-262 S1-245 QK1312 Q1319
	P10 (8) N2-CS55×36		378	200	55	158	36	36	56	77	30'	S1-262 S1-245
D	P10 (8) N2-DS55×36	9 $\frac{5}{8}$ "~13 $\frac{3}{8}$ "	395	200	55	175	36	43	60	81	15'	S1-262 S1-245

Accessory	Insert	Shim	Oblique rod	Lock screw	Wrench
Image					
Ordering code	B8N2-3H B10N2-4H	169. 523	Φ4 Oblique rod	M6	S3

Threading
Thread Toolholder for Oil Pipe

Round tool shank for papilionaceous round internal threading inserts

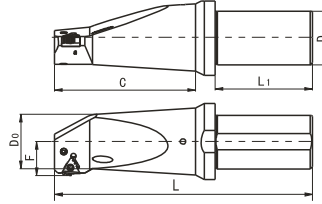

Type	Ordering code	Working range	Dimension							Machine tool
			L	L ₁	D	C	D ₀	F	λ	
A	P10 (8) N2-AR40×80	2 $\frac{3}{8}$ "~3 $\frac{1}{2}$ "	205	80	40	100	42	26	70'	CK7815 CK7620
	P10 (8) N2-AR50×90		215	90	50	100	42	26	70'	CK7832 CK3263A
	P10 (8) N2-AR60×100		225	100	60	100	42	26	70'	CK7840
	P10 (8) N2-AR80×140		265	140	80	100	42	26	70'	CK3263B
	P10 (8) N2-AR60×140 (A1)	2 $\frac{3}{8}$ "	265	140	60	85	45	26.5	70'	-
	P10 (8) N2-AR60×140 (A2)	2 $\frac{7}{8}$ "~3 $\frac{1}{2}$ "	275	140	60	95	50	30.5	70'	-
B	P10 (8) N2-BR40×80	4"~5 $\frac{1}{2}$ "	235	80	40	130	50	31	50'	CK7815 CK7620
	P10 (8) N2-BR50×90		245	90	50	130	50	31	50'	CK7832 CK3263A
	P10 (8) N2-BR60×100		255	100	60	130	50	31	50'	CK7840
	P10 (8) N2-BR80×140		295	140	80	130	50	31	50'	CK3263B
C	P10 (8) N2-CR50×90	6 $\frac{5}{8}$ "~8 $\frac{5}{8}$ "	268	90	50	158	56	36	30'	CK7840
	P10 (8) N2-CR60×100		278	100	60	158	56	36	30'	CK3263B
	P10 (8) N2-CR80×140		318	140	80	158	56	36	30'	CK7832 CK3263A
D	P10 (8) N2-DR60×100	9 $\frac{5}{8}$ "~13 $\frac{3}{8}$ "	295	100	60	175	60	43	15'	CK7840
	P10 (8) N2-DR80×140		335	140	80	175	60	43	15'	CK3263B

Accessory	Insert	Shim	Oblique rod	Lock screw	Wrench
Image					
Ordering code	B8N2-3H B10N2-4H	169. 523	Φ4 Oblique rod	M6	S3

Square tool shank for papilionaceous buttress internal threading inserts

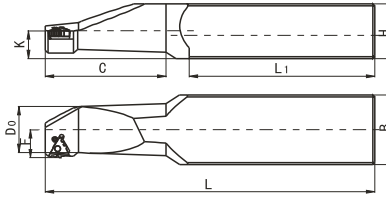

Type	Ordering code	Working range	Dimension									Machine tool
			L	L ₁	H	C	K	F	D ₀	B	λ	
B	P5BN2-BS48×32	4"~5 $\frac{1}{2}$ "	335	180	48	130	32	31	50	74	60'	S1-127 S1-344
	P5BN2-BS55×36		355	200	55	130	36	31	50	77	60'	
C	P5BN2-CS48×32	6 $\frac{5}{8}$ "~8 $\frac{5}{8}$ "	358	180	48	158	32	36	56	74	40'	S1-127 S1-344
	P5BN2-CS55×36		378	200	55	158	36	36	56	77	40'	
D	P5BN2-DS55×36	9 $\frac{5}{8}$ "~13 $\frac{3}{8}$ "	395	200	55	175	36	43	60	81	20'	S1-245 S1-262

Accessory	Insert	Shim	Oblique rod	Lock screw	Wrench
Image					
Ordering code	B5BN2-3	169. 973	Φ4 Oblique rod	M6	S3

Threading
Thread Toolholder for Oil Pipe

Round tool shank for papilionaceous buttress internal threading inserts

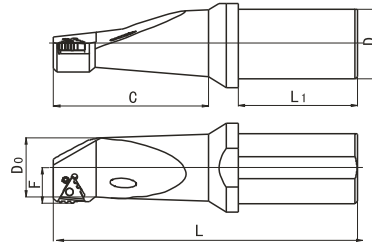

(mm)

Type	Ordering code	Working range	Dimension							Machine tool
			L	L ₁	D	C	D ₀	F	λ	
B	P5BN2-BR50×90	4 $\frac{1}{2}$ "~6 $\frac{5}{8}$ "	245	90	50	130	50	31	60'	CK7820 CK7832
	P5BN2-BR60×100		255	100	60	130	50	31	60'	CK7840 S1-181
	P5BN2-BR80×140		295	140	80	130	50	31	60'	CK3263
C	P5BN2-CR60×100	7"~11 $\frac{3}{4}$ "	283	100	60	158	56	36	40'	CK7820 CK7832
	P5BN2- CR80×140		323	140	80	158	56	36	40'	CK3263
D	P5BN2- DR60×100	13 $\frac{3}{8}$ "~20"	300	100	60	175	60	43	20'	CK7840 S1-181
	P5BN2- Dr80×140		340	140	80	175	60	43	20'	CK3263

Accessory	Insert	Shim	Oblique rod	Lock screw	Wrench
Image					
Ordering code	B5BN2-3	169.973	φ4 Oblique rod	M6	S3

Threading
Thread Toolholder for Oil Pipe

Tool shank for papilionaceous buttress external threading inserts

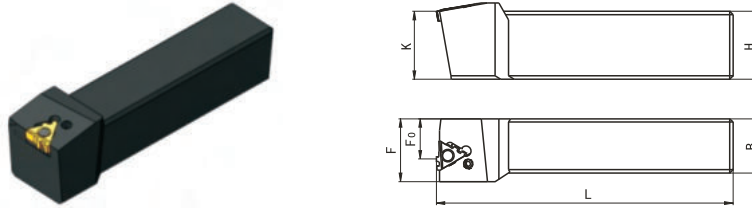

Type	Ordering code	Working range	Dimension							Machine tool
			L	H	K	B	F	F ₀	λ	
B	P5BW2-B35×32	4"~5 $\frac{1}{2}$ "	175	35	32	35	40	25	60'	QK1312
C	P5BW2-C35×32	6 $\frac{5}{8}$ "~8 $\frac{5}{8}$ "	175	35	32	35	40	25	40'	S1-245
D	P5BW2-D35×32	9 $\frac{5}{8}$ "~13 $\frac{3}{8}$ "	175	35	32	35	40	25	20'	S1-127

Accessory	Insert	Shim	Oblique rod	Lock screw	Wrench
Image					
Ordering code	B5BW2-2	169.798	φ4 Oblique rod	M6	S3

Insert
External Toolholder
Internal Toolholder
Threading
Parting, Grooving
Miniature Tool

PARTING, GROOVING



Turnline TKD Series ----- P80-P82

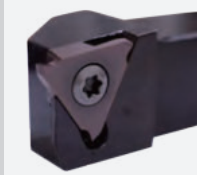

Turnline GB Series ----- P83-P85

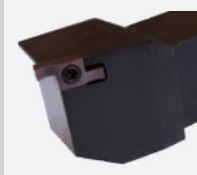

Turnline TGE Series ----- P86-P91



Turnline TTF Series ----- P92-P94



Turnline TTS Series ----- P95

MINIATURE TOOL



Solid Boring Bar ----- P96-P107



Modular Small Hole Cutter ----- P108-P109

Turnline TKD Series
Insert for Parting Grooving & Turning

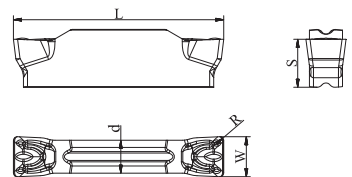
<p>TKD-MT</p> 					
<p>Order No .</p>	<p>Dimension (mm)</p>				
	<p>W</p>	<p>R</p>	<p>L</p>	<p>d</p>	<p>S</p>
<p>TKD 2002 - MT</p>	<p>2</p>	<p>0.2</p>	<p>16</p>	<p>1.2</p>	<p>3.5</p>
<p>TKD 2502 - MT</p>	<p>2.5</p>	<p>0.2</p>	<p>18.5</p>	<p>2</p>	<p>3.85</p>
<p>TKD 3004 - MT</p>	<p>3</p>	<p>0.4</p>	<p>21.2</p>	<p>2.35</p>	<p>4.8</p>
<p>TKD 4004 - MT</p>	<p>4</p>	<p>0.4</p>	<p>21</p>	<p>3.3</p>	<p>4.8</p>
<p>TKD 5004 - MT</p>	<p>5</p>	<p>0.4</p>	<p>26</p>	<p>4.1</p>	<p>5.8</p>
<p>TKD 5008 - MT</p>	<p>5</p>	<p>0.8</p>	<p>26</p>	<p>4.1</p>	<p>5.8</p>
<p>TKD 6004 - MT</p>	<p>6</p>	<p>0.4</p>	<p>26</p>	<p>5</p>	<p>5.8</p>
<p>TKD 6008 - MT</p>	<p>6</p>	<p>0.8</p>	<p>26</p>	<p>5</p>	<p>5.8</p>

Grade: TG4230
 Working Materials: Steel
 Stainless Steel
 Cast Iron

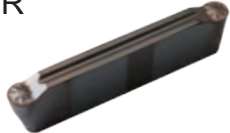
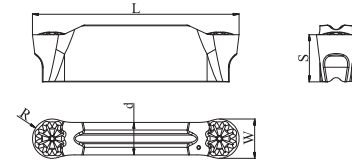
<p>TKD-MR</p> 					
<p>Order No .</p>	<p>Dimension (mm)</p>				
	<p>W</p>	<p>R</p>	<p>L</p>	<p>d</p>	<p>S</p>
<p>TKD 2010 - MR</p>	<p>2</p>	<p>1</p>	<p>16</p>	<p>1.5</p>	<p>3.5</p>
<p>TKD 3015 - MR</p>	<p>3</p>	<p>1.5</p>	<p>21</p>	<p>2.35</p>	<p>4.8</p>
<p>TKD 4020 - MR</p>	<p>4</p>	<p>2</p>	<p>21</p>	<p>3.3</p>	<p>4.8</p>
<p>TKD 5025 - MR</p>	<p>5</p>	<p>2.5</p>	<p>26</p>	<p>4.1</p>	<p>5.8</p>
<p>TKD 6030 - MR</p>	<p>6</p>	<p>3</p>	<p>26</p>	<p>5</p>	<p>5.8</p>

Grade: TG4230
 Working Materials: Steel
 Stainless Steel
 Cast Iron

Insert
 External Toolholder
 Internal Toolholder
 Threading
 Parting, Grooving
 Miniature Tool

Turnline TKD Series
External Toolholders for Grooving, Parting & Turning

MGEHR/L

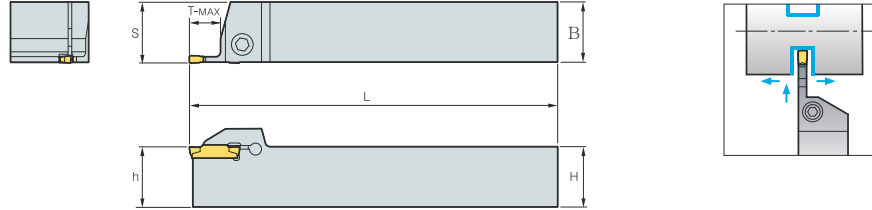

(mm)

Order No.	Dimension (mm)							Insert	Wrench	Screw
	W	T-MAX	H	B	L	S	h			
MGEHR/L1212-2.0	2	12	12	12	100	13	12	TKD20 .MT TKD20 .MR	L3	BHA0410
MGEHR/L1616-2.0	2	14	16	16	100	17	16			
MGEHR/L2020-2.0	2	14	20	20	125	21	20	TKD25 .MT TKD25 .MR	L5	BHA0616
MGEHR/L2525-2.0	2	14	25	25	150	26	25			
MGEHR/L1616-2.5	2.5	16	16	16	100	17	16	TKD25 .MT TKD25 .MR	L5	BHA0616
MGEHR/L2020-2.5	2.5	16	20	20	125	21	20			
MGEHR/L2525-2.5	2.5	16	25	25	150	26	25	TKD30 .MT TKD30 .MR	L3	BHA0410
MGEHR/L1212-3.0	3	16	12	12	100	13	12			
MGEHR/L1616-3.0	3	18	16	16	100	17	16	TKD30 .MT TKD30 .MR	L5	BHA0410
MGEHR/L2020-3.0	3	18	20	20	125	21	20			
MGEHR/L2525-3.0	3	18	25	25	150	26	25	TKD40 .MT TKD40 .MR	L5	BHA0410
MGEHR/L3232-3.0	3	18	32	32	170	33	32			
MGEHR/L1616-4.0	4	18	16	16	100	17	16	TKD40 .MT TKD40 .MR	L5	BHA0410
MGEHR/L2020-4.0	4	18	20	20	125	21	20			
MGEHR/L2525-4.0	4	18	25	25	150	26	25	TKD50 .MT TKD50 .MR	L5	BHA0410
MGEHR/L3232-4.0	4	18	32	32	170	33	32			
MGEHR/L2020-5.0	5	23	20	20	125	21	20	TKD50 .MT TKD50 .MR	L5	BHA0410
MGEHR/L2525-5.0	5	23	25	25	150	26	25			
MGEHR/L3232-5.0	5	23	32	32	170	33	32	TKD60 .MT TKD60 .MR	L5	BHA0410
MGEHR/L2525-6.0	6	25	25	25	150	26	25			
MGEHR/L3232-6.0	6	25	32	32	170	33	32	TKD60 .MT TKD60 .MR	L5	BHA0410

Turnline TKD Series
Boring Bar for Internal Grooving & Turning

MGIVR/L

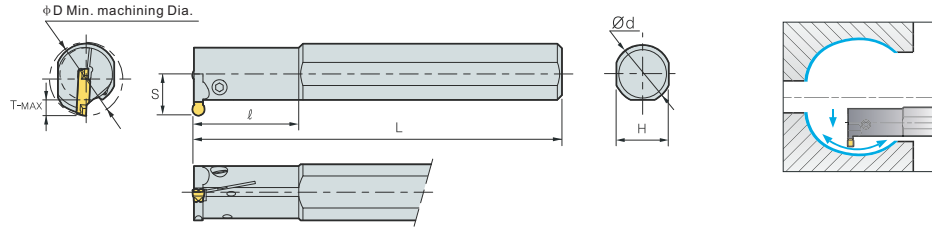

Order No.	Dimension (mm)								Insert	Wrench	Screw
	W	T-MAX	D	d	L	S	H	I			
MGIVR/L2016-2.0	2	4.5	20	16	125	12.4	15	35	TKD20 .MT TKD20 .MR	L3	BH0410
MGIVR/L2520-2.0	2	4.5	25	20	150	14	18	45			BHA0512
MGIVR/L2925-2.0	2	4.5	29	25	200	17.2	23	45	TKD25 .MT TKD25 .MR	L4	BHA0516
MGIVR/L2016-2.5	2.5	4.5	20	16	125	12.5	15	35			BH0410
MGIVR/L2520-2.5	2.5	4.5	25	20	150	15.1	18	45	TKD25 .MT TKD25 .MR	L4	BHA0512
MGIVR/L2925-2.5	2.5	4.5	29	25	200	18.2	23	45			BHA0516
MGIVR/L2520-3.0	3	5	25	20	150	15.6	18	45	TKD30 .MT TKD30 .MR	L4	BHA0512
MGIVR/L3125-3.0	3	6	31	25	200	18.9	23	45			BHA0516
MGIVR/L3732-3.0	3	6	37	32	250	21.5	30	60	TKD40 .MT TKD40 .MR	L4	BHA0512
MGIVR/L2520-4.0	4	6	25	20	150	15.6	18	45			BHA0516
MGIVR/L3125-4.0	4	6	31	25	200	18.9	23	45	TKD50 .MT TKD50 .MR	L4	BHA0512
MGIVR/L3732-4.0	4	6	37	32	250	21.5	30	60			BHA0516
MGIVR/L3125-5.0	5	8	31	25	200	19.4	23	45	TKD60 .MT TKD60 .MR	L4	BHA0516
MGIVR/L3732-5.0	5	8	37	32	250	21.4	30	60			BHA0516
MGIVR/L3125-6.0	6	8	31	25	200	19.4	23	45	TKD60 .MT TKD60 .MR	L4	BHA0516
MGIVR/L3732-6.0	6	8	37	32	250	21.4	30	60			BHA0516

TKD Series Standard Cutting Conditions

ISO	Workpiece Material	Vc(m/min)	Grooving				Turning			
			Edge Width (mm)				Edge Width (mm)			
			2-3	4	5	6	2-3	4	5	6
			f(mm/min)				f(mm/min)			
P	Carbon Steel	80-200	0.05-0.15	0.10-0.20	0.15-0.25	0.15-0.30	0.10-0.25	0.10-0.30	0.15-0.30	0.20-0.35
	Alloy Steel	70-180	0.05-0.15	0.10-0.20	0.15-0.25	0.15-0.30	0.10-0.25	0.10-0.30	0.15-0.30	0.20-0.35
M	Stainless Steel	60-150	0.05-0.15	0.10-0.20	0.15-0.25	0.15-0.30	0.10-0.25	0.10-0.30	0.15-0.30	0.20-0.35
K	Cast Iron	100-200	0.05-0.20	0.10-0.25	0.15-0.30	0.15-0.35	0.10-0.30	0.10-0.35	0.15-0.35	0.20-0.40

Turnline GB Series
Inserts for Shallow Grooving

Insert
 External Toolholder
 Internal Toolholder
 Threading
 Parting, Grooving
 Miniature Tool

Order No.	Dimension (mm)							
	W	CD	r	IC	T	d1	R	L
GB3075R/L -010	0.75	2.0	0.1	9.525	3.18	4.4	●	○
GB3080R/L -005	0.80		0.05	9.525	3.18	4.4	●	○
GB3095R/L -010	0.95		0.1	9.525	3.18	4.4	●	○
GB3100R/L -005	1.00		0.05	9.525	3.18	4.4	●	○
GB3100R/L -010	1.00		0.1	9.525	3.18	4.4	●	○
GB3120R/L -010	1.20		0.1	9.525	3.18	4.4	●	○
GB3120R/L -020	1.20		0.2	9.525	3.18	4.4	●	○
GB3125R/L -010	1.25		0.1	9.525	3.18	4.4	●	○
GB3140R/L -010	1.40		0.1	9.525	3.18	4.4	●	○
GB3140R/L -020	1.40		0.2	9.525	3.18	4.4	●	●
GB3150R/L -010	1.50		0.1	9.525	3.18	4.4	●	○
GB3150R/L -020	1.50		0.2	9.525	3.18	4.4	●	●
GB3175R/L -010	1.75		0.1	9.525	3.18	4.4	●	○
GB3200R/L -010	2.00		2.5	0.1	9.525	3.18	4.4	●
GB3200R/L -020	2.00	0.2		9.525	3.18	4.4	●	●
GB3250R/L -010	2.50	0.1		9.525	3.18	4.4	●	○
GB3250R/L -020	2.50	0.2		9.525	3.18	4.4	●	●
GB3300R/L -020	3.00	0.2		9.525	3.18	4.4	●	●
GB4125R/L -020	1.25	2.0	0.2	12.7	4.76	5.5	●	●
GB4150R/L -010	1.50	3.5	0.1	12.7	4.76	5.5	●	○
GB4150R/L -020	1.50		0.2	12.7	4.76	5.5	●	●
GB4175R/L -020	1.75		0.2	12.7	4.76	5.5	●	○
GB4185R/L -020	1.85		0.2	12.7	4.76	5.5	●	●
GB4200R/L -005	2.00		0.05	12.7	4.76	5.5	●	○
GB4200R/L -010	2.00		0.1	12.7	4.76	5.5	●	○
GB4200R/L -020	2.00		0.2	12.7	4.76	5.5	●	●
GB4200R/L -030	2.00		0.3	12.7	4.76	5.5	●	○
GB4200R/L -050	2.00		0.5	12.7	4.76	5.5	●	○
GB4250R/L -030	2.50		0.3	12.7	4.76	5.5	●	●
GB4265R/L -030	2.65	4.0	0.3	12.7	4.76	5.5	●	○
GB4280R/L -030	2.80		0.3	12.7	4.76	5.5	●	○
GB4300R/L -030	3.00		0.3	12.7	4.76	5.5	●	●
GB4330R/L -030	3.30	5.0	0.3	12.7	4.76	5.5	●	○
GB4350R/L -030	3.50		0.3	12.7	4.76	5.5	●	●
GB4400R/L -040	4.00		0.4	12.7	4.76	5.5	●	●
GB4430R/L -040	4.30		0.4	12.7	4.76	5.5	●	○

● : Stock ○ : Non- Stock

Grade: TG4230
 Working Materials: Steel
 Stainless Steel
 Cast Iron

Turnline GB Series
Inserts for Shallow Grooving

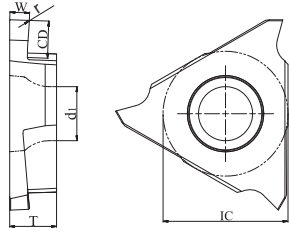
<p>GBR</p> 								
	Dimension (mm)							
Order No.	W	CD	r	IC	T	d1	R	L
GBR4100R/L -050	1.00	2.0	0.50	12.70	4.76	5.50	●	●
GBR4150R/L -075	1.50	3.5	0.75	12.70	4.76	5.50	●	●
GBR4200R/L -100	2.00	3.5	1.00	12.70	4.76	5.50	●	●
GBR4250R/L -125	2.50	4.0	1.25	12.70	4.76	5.50	●	●
GBR4300R/L -150	3.00	4.0	1.50	12.70	4.76	5.50	●	●
GBR4400R/L -200	4.00	5.0	2.00	12.70	4.76	5.50	●	●

Grade: TG4230
 Working Materials: Steel
 Stainless Steel
 Cast Iron

GB/GBR Series Standard Cutting Conditions

ISO	Workpiece Material	Vc(m/min)	Grooving					Turning				
			Edge Width (mm)					Edge Width (mm)				
			0.75-1.00	1.20-2.00	2.50-3.00	3.30-4.00	4.30	0.75-1.00	1.20-2.00	2.50-3.00	3.30-4.00	4.30
			f(mm/min)					f(mm/min)				
P	Carbon Steel	80-200	0.03-0.08	0.04-0.09	0.05-0.10	0.05-0.12	0.05-0.12	—	0.04-0.09	0.05-0.10	0.05-0.10	0.05-0.10
	Alloy Steel	80-180	0.03-0.07	0.04-0.08	0.05-0.09	0.05-0.10	0.05-0.10	—	0.04-0.08	0.05-0.09	0.05-0.10	0.05-0.10
M	Stainless Steel	60-150	0.03-0.07	0.04-0.08	0.05-0.09	0.05-0.10	0.05-0.10	—	0.04-0.08	0.05-0.09	0.05-0.10	0.05-0.10
K	Cast Iron	80-180	0.03-0.08	0.04-0.09	0.05-0.10	0.05-0.12	0.05-0.12	—	0.04-0.09	0.05-0.10	0.05-0.10	0.05-0.10

Turnline GB Series
Toolholders for Shallow Grooving

GB Series External Toolholders

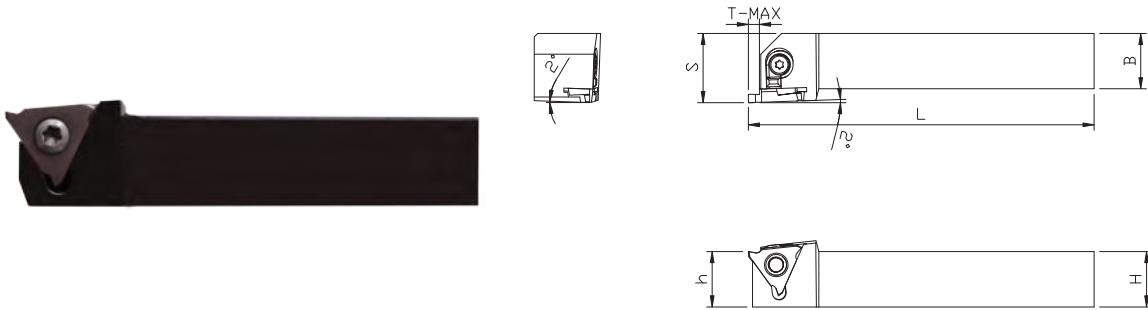

Order No.	Dimension (mm)						Insert	Wrench	Screw
	T-MAX	H	B	L	S	h			
GBER2020K3	2.5	20	20	125	25	20	GB3...	TT15P	SI60M 035120
GBER2525M3	2.5	25	25	150	30	25			
GBER2020K4-15	4.0	20	20	125	25	20	GB4/GBR4... (1.0 ≤ W < 2.5)	TT20P	SI60M 050120
GBER2525M4-15	4.0	25	25	150	30	25			
GBER2020K4-25	4.5	20	20	125	25	20	GB4/GBR4... (2.5 ≤ W < 3.3)		
GBER2525M4-25	4.5	25	25	150	30	25			
GBER2020K4-35	5.5	20	20	125	25	20	GB4/GBR4... (3.3 ≤ W < 4.8)		
GBER2525M4-35	5.5	25	25	150	30	25			

GB Series Internal Toolholders

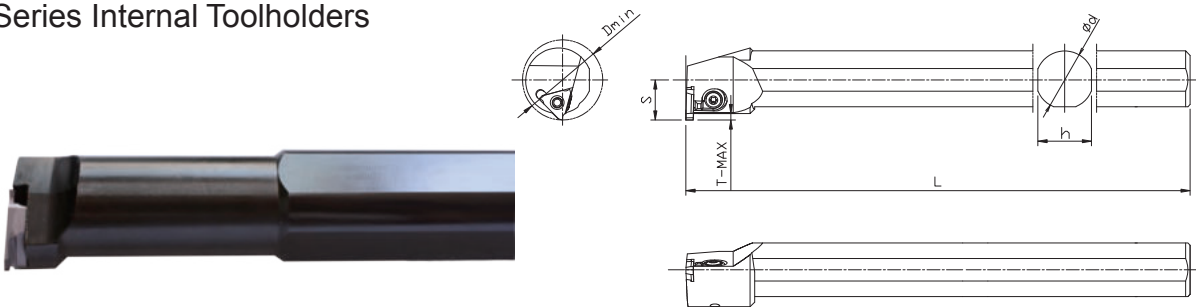

Order No.	Dimension (mm)						Insert	Wrench	Screw
	T-MAX	Dmin	Ød	L	S	h			
GBIR/L2620Q3	3.0	26	20	180	13	18	GB3...	TT15P	SI60M
GBIR/L3525R4	4.5	35	25	200	17.5	23	GB4/GBR4...	TT20P	SI60M



Turnline TGE Series
Inserts for Shallow Grooving

TGE Series Inserts for Grooving

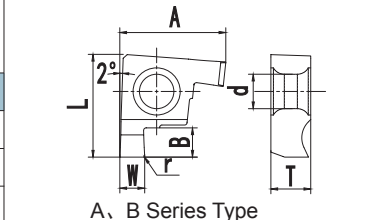
Model	A(mm)	L(mm)	T(mm)	d(mm)		
TGER**-A	6.69	6.50	2.58	2.5	● Good recommendation Material Recommended	Grade TG1225
TGER**-B	8.46	8.20	3.18	2.7		Steel P ●
TGER**-C	5.80	11.48	4.05	2.8		Stainless M ●
TGER**-D	6.80	16.44	5.05	3.4		Cast Iron K ●
TGER**-E	9.54	21.66	5.55	4.4		



A, B Series Type

Insert	Order No.		Dimensions(mm)			Toolholders
	Right hand	Left hand	W	B	r	
	TGER050-A	TGEL050-A	0.50	1.2	0.05	SIGER/L0808A-EH SIGER/L0808A-WH
	TGER060-A	TGEL060-A	0.60	1.2	0.05	
	TGER070-A	TGEL070-A	0.70	1.2	0.05	
	TGER080-A	TGEL080-A	0.80	1.2	0.05	
	TGER100-A	TGEL100-A	1.00	1.5	0.05	
	TGER120-A	TGEL120-A	1.20	1.5	0.05	
	TGER125-A	TGEL125-A	1.25	1.5	0.05	
	TGER140-A	TGEL140-A	1.40	1.5	0.10	
	TGER150-A	TGEL150-A	1.50	1.5	0.10	
	TGER180-A	TGEL180-A	1.80	1.5	0.10	
	TGER200-A	TGEL200-A	2.00	1.5	0.10	
	TGER080-B	TGEL080-B	0.80	1.8	0.05	SIGER/L1010B-EH SIGER/L1010B-WH SIGER/L1210B-EH
	TGER100-B	TGEL100-B	1.00	2.2	0.05	
	TGER120-B	TGEL120-B	1.20	2.2	0.05	
	TGER125-B	TGEL125-B	1.25	2.2	0.05	
	TGER130-B	TGEL130-B	1.30	2.2	0.10	
	TGER145-B	TGEL145-B	1.45	2.2	0.10	
	TGER150-B	TGEL150-B	1.50	2.2	0.10	
	TGER180-B	TGEL180-B	1.80	2.2	0.10	
	TGER200-B	TGEL200-B	2.00	2.2	0.10	
	TGER225-B	TGEL225-B	2.25	2.2	0.10	
	TGER250-B	TGEL250-B	2.50	2.2	0.10	
	TGER280-B	TGEL280-B	2.80	2.2	0.20	
	TGER300-B	TGEL300-B	3.00	2.2	0.20	
	TGER100-C	TGEL100-C	1.00	2.5	0.05	SIGER/L1412C-EH SIGER/L1612C-EH SIGER/L1616C-EH
	TGER120-C	TGEL120-C	1.20	2.5	0.05	
	TGER125-C	TGEL125-C	1.25	2.5	0.05	
	TGER140-C	TGEL140-C	1.40	2.5	0.10	
	TGER145-C	TGEL145-C	1.45	2.5	0.10	
	TGER150-C	TGEL150-C	1.50	2.5	0.10	
	TGER160-C	TGEL160-C	1.60	2.5	0.10	
	TGER170-C	TGEL170-C	1.70	2.5	0.10	
	TGER185-C	TGEL185-C	1.85	2.5	0.10	
	TGER195-C	TGEL195-C	1.95	2.5	0.10	
	TGER200-C	TGEL200-C	2.00	2.5	0.10	
	TGER225-C	TGEL225-C	2.25	2.5	0.10	
	TGER250-C	TGEL250-C	2.50	2.5	0.20	
	TGER275-C	TGEL275-C	2.75	2.5	0.20	
	TGER280-C	TGEL280-C	2.80	2.5	0.20	
	TGER300-C	TGEL300-C	3.00	2.5	0.20	
	TGER320-C	TGEL320-C	3.20	2.5	0.20	
TGER350-C	TGEL350-C	3.50	2.5	0.20		

Right-hand Insert for Right-hand Toolholder
Left-hand Insert for Left-hand Toolholder

Insert
External Toolholder
Internal Toolholder
Threading
Parting, Grooving
Miniature Tool

Turnline TGE Series
Inserts for Shallow Grooving

TGE Series Inserts for Grooving

Model	A(mm)	L(mm)	T (mm)	d(mm)	● Good recommendation	Material Recommended	
						Grade	TG1225
TGER**-A	6.69	6.50	2.58	2.5	●	Steel	P ●
TGER**-B	8.46	8.20	3.18	2.7	●	Stainless	M ●
TGER**-C	5.80	11.48	4.05	2.8	●	Cast Iron	K ●
TGER**-D	6.80	16.44	5.05	3.4	●		
TGER**-E	9.54	21.66	5.55	4.4	●		

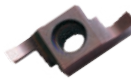
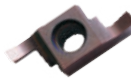
Insert	Order No.		Dimensions(mm)			Toolholders
	Right hand	Left hand	W	B	r	
	TGER100-D	TGEL100-D	1.00	2.5	0.05	SIGER/L2020D-EH SIGER/L2525D-EH
	TGER120-D	TGEL120-D	1.20	2.5	0.05	
	TGER125-D	TGEL125-D	1.25	2.5	0.05	
	TGER140-D	TGEL140-D	1.40	2.5	0.05	
	TGER145-D	TGEL145-D	1.45	2.5	0.10	
	TGER150-D	TGEL150-D	1.50	3.0	0.10	
	TGER170-D	TGEL170-D	1.70	3.0	0.10	
	TGER185-D	TGEL185-D	1.85	3.0	0.10	
	TGER195-D	TGEL195-D	1.95	3.0	0.10	
	TGER200-D	TGEL200-D	2.00	3.6	0.10	
	TGER225-D	TGEL225-D	2.25	3.6	0.10	
	TGER230-D	TGEL230-D	2.30	3.6	0.20	
	TGER250-D	TGEL250-D	2.50	3.6	0.20	
	TGER275-D	TGEL275-D	2.75	3.6	0.20	
	TGER280-D	TGEL280-D	2.80	4.5	0.20	
	TGER300-D	TGEL300-D	3.00	4.5	0.20	
	TGER320-D	TGEL320-D	3.20	4.5	0.20	
	TGER350-D	TGEL350-D	3.50	4.5	0.20	
TGER400-D	TGEL400-D	4.00	4.5	0.20		
	TGER100-E	TGEL100-E	1.00	2.5	0.05	SIGER/L2525E-EH SIGER/L3232E-EH SIGER/L4032E-EH
	TGER150-E	TGEL150-E	1.50	3.0	0.10	
	TGER170-E	TGEL170-E	1.70	3.0	0.10	
	TGER185-E	TGEL185-E	1.85	3.0	0.10	
	TGER195-E	TGEL195-E	1.95	3.0	0.10	
	TGER200-E	TGEL200-E	2.00	3.2	0.10	
	TGER225-E	TGEL225-E	2.25	3.2	0.10	
	TGER230-E	TGEL230-E	2.30	3.2	0.20	
	TGER250-E	TGEL250-E	2.50	4.5	0.20	
	TGER275-E	TGEL275-E	2.75	4.5	0.20	
	TGER280-E	TGEL280-E	2.80	4.5	0.20	
	TGER300-E	TGEL300-E	3.00	4.5	0.20	
	TGER330-E	TGEL330-E	3.30	4.5	0.20	
	TGER350-E	TGEL350-E	3.50	5.5	0.20	
	TGER400-E	TGEL400-E	4.00	5.5	0.20	
	TGER430-E	TGEL430-E	4.30	5.5	0.20	
	TGER450-E	TGEL450-E	4.50	6.5	0.20	
	TGER460-E	TGEL460-E	4.60	6.5	0.20	
TGER500-E	TGEL500-E	5.00	6.5	0.20		

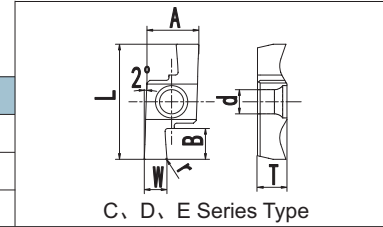



Right-hand Insert for Right-hand Toolholder
 Left-hand Insert for Left-hand Toolholder

Turnline TGE Series
Inserts for Shallow Grooving

TGE Series Inserts for Grooving

Model	A(mm)	L(mm)	T(mm)	d(mm)										
TGER**-A	6.69	6.5	2.58	2.5	● Good recommendation Material Recommended	<table border="1"> <tr> <td>Grade</td> <td>TG1225</td> </tr> <tr> <td>Steel</td> <td>P ●</td> </tr> <tr> <td>Stainless</td> <td>M ●</td> </tr> <tr> <td>Cast Iron</td> <td>K ●</td> </tr> </table>	Grade	TG1225	Steel	P ●	Stainless	M ●	Cast Iron	K ●
Grade	TG1225													
Steel	P ●													
Stainless	M ●													
Cast Iron	K ●													
TGER**-B	8.46	8.2	3.18	2.7										
TGER**-C	5.8	11.48	4.05	2.8										
TGER**-D	6.8	16.44	5.05	3.4										
TGER**-E	9.54	21.66	5.55	4.4										

Insert	Order No.		Dimensions(mm)			Toolholders
	Right hand	Left hand	W	B	r	
	TGER100-050AR	TGEL100-050AR	1.0	1.5	0.50	SIGER/L0808A-EH SIGER/L0808A-WH
	TGER150-075AR	TGEL150-075AR	1.5	1.5	0.75	
	TGER200-100AR	TGEL200-100AR	2.0	1.5	1.00	
	TGER100-050BR	TGEL100-050BR	1.0	2.2	0.50	SIGER/L1010B-EH SIGER/L1010B-WH SIGER/L1210B-EH
	TGER150-075BR	TGEL150-075BR	1.5	2.2	0.75	
	TGER200-100BR	TGEL200-100BR	2.0	2.2	1.00	
	TGER250-125BR	TGEL250-125BR	2.5	2.2	1.25	
	TGER300-150BR	TGEL300-150BR	3.0	2.2	1.50	
	TGER100-050CR	TGEL100-050CR	1.0	2.5	0.50	SIGER/L1412C-EH SIGER/L1612C-EH SIGER/L1616C-EH
	TGER150-075CR	TGEL150-075CR	1.5	2.5	0.75	
	TGER200-100CR	TGEL200-100CR	2.0	2.5	1.00	
	TGER250-125CR	TGEL250-125CR	2.5	2.5	1.25	
	TGER300-150CR	TGEL300-150CR	3.0	2.5	1.50	
	TGER150-075DR	TGEL150-075DR	1.5	3.2	0.75	SIGER/L2020D-EH SIGER/L2525D-EH
	TGER200-100DR	TGEL200-100DR	2.0	3.2	1.00	
	TGER250-125DR	TGEL250-125DR	2.5	4.5	1.25	
	TGER300-150DR	TGEL300-150DR	3.0	4.5	1.50	SIGER/L2525E-EH SIGER/L3232E-EH SIGER/L4032E-EH
	TGER250-125ER	TGEL250-125ER	2.5	5.5	1.25	
	TGER300-150ER	TGEL300-150ER	3.0	5.5	1.50	
	TGER350-175ER	TGEL350-175ER	3.5	5.5	1.75	
	TGER400-200ER	TGEL400-200ER	4.0	6.5	2.00	
	TGER450-225ER	TGEL450-225ER	4.5	6.5	2.25	
	TGER500-250ER	TGEL500-250ER	5.0	6.5	2.50	

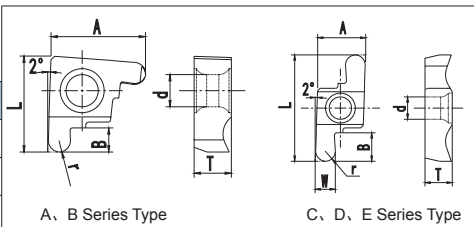

Right-hand Insert for Right-hand Toolholder
Left-hand Insert for Left-hand Toolholder

Insert
External Toolholder
Internal Toolholder
Threading
Parting, Grooving
Miniature Tool

Turnline TGE Series
Toolholders for Shallow Grooving

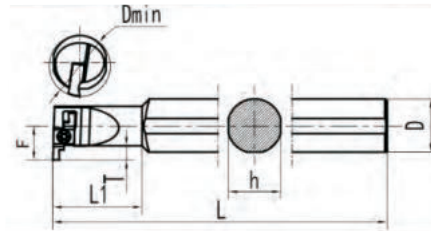
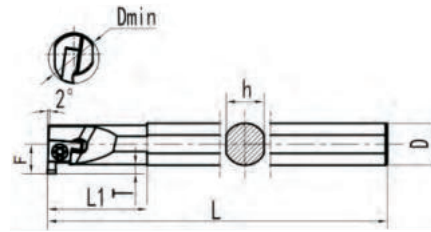

TGE Series Toolholders for Grooving



Order No.	Insert	Dimensions (mm)							Insert Screw	Torx Key
		Dmin	T	L1	D	F	h	L		
SIGER0808A-EH	TGER**A	8	1.5	20	8	4.8	7.2	100	L60M225	T6
SIGER0808A-WH	TGER**AR	8		20	8	4.8	7.2	100		
SIGER1010B-EH	TGER**B TGER**BR	10	2.2	25	10	6.2	9.0	125	L60M256	T8
SIGER1010B-WH		10		25	10	6.2	9.0	125		
SIGER1210B-EH		12		30	10	7.0	9.0	125		
SIGER1412C-EH	TGER**C TGER**CR	14	2.5	33	12	8.0	11.4	150	L60M256	T8
SIGER1612C-EH		16		20	12	8.5	11.4	150		
SIGER1616C-EH		16		36	16	9.0	15.0	160		
SIGER2020D-EH	TGER**D	20	4.5	40	20	12.1	19.0	180	L60M38	T10
SIGER2525D-EH	TGER**DR	25	4.2	45	25	12.3	24.0	200		
SIGER2525E-EH	TGER**E TGER**ER	25	6.5	45	25	15.6	24.0	200	L60M485	T15
SIGER3232E-EH		32		55	32	19.0	30.4	220		
SIGER4032E-EH		40		45	32	23.0	30.4	250		
SIGEL0808A-EH	TGEL**A	8	1.5	20	8	4.8	7.2	100	L60M225	T6
SIGEL0808A-WH	TGEL**AR	8		20	8	4.8	7.2	100		
SIGEL1010B-EH	TGEL**B TGEL**BR	10	2.2	25	10	6.2	9.0	125	L60M256	T8
SIGEL1010B-WH		10		25	10	6.2	9.0	125		
SIGEL1210B-EH		12		30	10	7.0	9.0	125		
SIGEL1412C-EH	TGEL**C TGEL**CR	14	2.5	33	12	8.0	11.4	150	L60M256	T8
SIGEL1612C-EH		16		20	12	8.5	11.4	150		
SIGEL1616C-EH		16		36	16	9.0	15.0	160		
SIGEL2020D-EH	TGEL**D	20	4.5	40	20	12.1	19.0	180	L60M38	T10
SIGEL2525D-EH	TGEL**DR	25	4.2	45	25	12.3	24.0	200		
SIGEL2525E-EH	TGEL**E TGEL**ER	25	6.5	45	25	15.6	24.0	200	L60M485	T15
SIGEL3232E-EH		32		55	32	19.0	30.4	220		
SIGEL4032E-EH		40		45	32	23.0	30.4	250		

Turnline TGE Series
Shallow Face Grooving

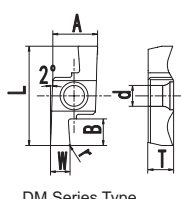
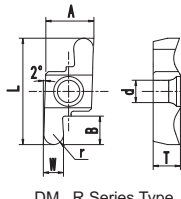
TGE Series Inserts for Face Grooving

Model	A(mm)	L(mm)	T (mm)	d(mm)			
TGER**-D	6.8	16.44	5.05	3.4	● Good recommendation		
					Material Recommended	Grade TG1225	
						Steel P ●	
						Stainless M ●	
						Cast Iron K ●	
						 DM Series Type	 DM...R Series Type
Insert	Order No.	External Dia. of the Groove	Dimensions (mm)			Toolholders	
			W	B	r		
	TGER200DM10-D	>10mm	2.0	3.5	0.20	SEGEL1010H-D SEGEL1212H-D SEGEL1616K-D SEGEL2020K-D SEGEL2525M-D	
	TGER250DM15-D	>15mm	2.5	4.5	0.20		
	TGER300DM15-D	>15mm	3.0	4.5	0.20		
	TGER400DM15-D	>15mm	4.0	4.5	0.20		
	TGER200DM10R100-D	>10mm	2.0	3.5	1.00		
	TGER250DM15R125-D	>15mm	2.5	4.5	1.25		
	TGER300DM15R150-D	>15mm	3.0	4.5	1.50		
	TGER400DM15R200-D	>15mm	4.0	4.5	2.00		

TGE Series Toolholders for Face Grooving

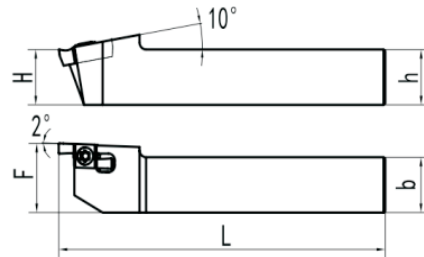

Order No.	Insert Type	Dimensions(mm)					Insert Screw	Torx Key
		h	b	L	F	H		
SEGEL1010K-D	TGER**-D	10	10	125	10	10	L60M310	T10
SEGEL1212K-D		12	12	125	12	12		
SEGEL1616H-D		16	16	100	20	16		
SEGEL2020K-D		20	20	125	25	20		
SEGEL2525M-D		25	25	150	32	25		

Insert
 External Toolholder
 Internal Toolholder
 Threading
 Parting, Grooving
 Miniature Tool

Turnline TGE Series
Standard Cutting Conditions

TGER/L...A(R),TGER/L...B(R) Series

ISO	Workpiece material	Vc(m/min)	Grooving			Turning		
			TGER/L050-200A	TGER/L080-200B	TGER/L225-200B	TGER/L050-200A	TGER/L080-200B	TGER/L225-200B
			TGER/L100-200AR	TGER/L100-200BR	TGER/L250-300BR	TGER/L100-200AR	TGER/L100-200BR	TGER/L250-300BR
			f(mm/min)			f(mm/min)		
P	Carbon Steel	50-80	0.01-0.03	0.02-0.04	0.02-0.04	0.01-0.03	0.02-0.04	0.02-0.04
	Alloy Steel	50-80	0.01-0.03	0.02-0.04	0.02-0.04	0.01-0.03	0.02-0.04	0.02-0.04
M	Stainless Steel	50-80	0.01-0.03	0.01-0.03	0.01-0.03	0.01-0.03	0.01-0.03	0.01-0.03
K	Cast Iron	50-80	0.01-0.03	0.02-0.04	0.02-0.04	0.01-0.03	0.02-0.04	0.02-0.04

TGER/L...C(R),TGER/L...D(R) ,TGER/L...E(R) Series

ISO	Workpiece material	Vc(m/min)	Grooving						
			TGER/L100-200C	TGER/L225-350C	TGER/L200-280D	TGER/L250-330E(R)	TGER/L300-400D	TGER/L350-430E(R)	TGER/L450-500E(R)
			TGER/L100-200CR	TGER/L250-300CR	TGER/L150-200DR	—	TGER/L300DR	—	—
			TGER/L100-145D	TGER/L150-195D	TGER/L200-230E(R)	—	—	—	—
			TGER/L100E(R)	TGER/L150-195E(R)	—	—	—	—	—
f(mm/min)									
P	Carbon Steel	60-140	0.03-0.08	0.03-0.08	0.04-0.09	0.04-0.09	0.05-0.12	0.05-0.12	0.05-0.12
	Alloy Steel	60-120	0.03-0.07	0.03-0.07	0.04-0.08	0.04-0.08	0.05-0.10	0.05-0.10	0.05-0.10
M	Stainless Steel	60-110	0.03-0.07	0.03-0.07	0.04-0.08	0.04-0.08	0.05-0.10	0.05-0.10	0.05-0.10
K	Cast Iron	60-100	0.03-0.08	0.03-0.08	0.04-0.09	0.04-0.09	0.05-0.12	0.05-0.12	0.05-0.12

ISO	Workpiece material	Vc(m/min)	Turning						
			TGER/L100-200C	TGER/L225-350C	TGER/L200-280D	TGER/L250-330E(R)	TGER/L300-400D	TGER/L350-430E(R)	TGER/L450-500E(R)
			TGER/L100-200CR	TGER/L250-300CR	TGER/L150-200DR	—	TGER/L300DR	—	—
			TGER/L100-145D	TGER/L150-195D	TGER/L200-230E(R)	—	—	—	—
			TGER/L100E(R)	TGER/L150-195E(R)	—	—	—	—	—
f(mm/min)									
P	Carbon Steel	60-140	0.03-0.08	0.03-0.08	0.04-0.09	0.04-0.09	0.05-0.10	0.05-0.10	0.05-0.10
	Alloy Steel	60-120	0.03-0.10	0.03-0.10	0.04-0.08	0.04-0.08	0.05-0.10	0.05-0.10	0.05-0.10
M	Stainless Steel	60-110	0.03-0.10	0.03-0.10	0.04-0.08	0.04-0.08	0.05-0.10	0.05-0.10	0.05-0.10
K	Cast Iron	60-100	0.03-0.08	0.03-0.08	0.04-0.09	0.04-0.09	0.05-0.10	0.05-0.10	0.05-0.10

TGER...DM Series

ISO	Workpiece Material	Vc(m/min)	Grooving			Turning		
			TGER200DM	TGER250DM	TGER300-400DM	TGER200DM	TGER250DM	TGER300-400DM
			f(mm/min)			f(mm/min)		
P	Carbon Steel	60-160	0.03-0.10	0.04-0.12	0.05-0.12	0.03-0.10	0.04-0.10	0.05-0.10
	Alloy Steel	60-140	0.03-0.10	0.04-0.12	0.05-0.12	0.03-0.10	0.04-0.10	0.05-0.10
M	Stainless Steel	60-110	0.03-0.08	0.04-0.08	0.05-0.10	0.03-0.10	0.04-0.10	0.05-0.10
K	Cast Iron	60-100	0.03-0.10	0.04-0.12	0.05-0.12	0.03-0.10	0.04-0.10	0.05-0.10

Turnline TTF Series
Inserts for P Parting

◆ Inserts Identification System

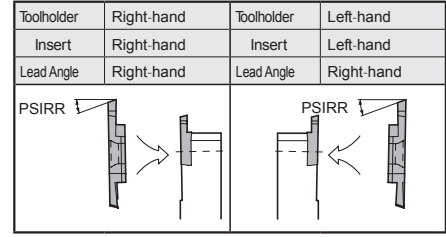
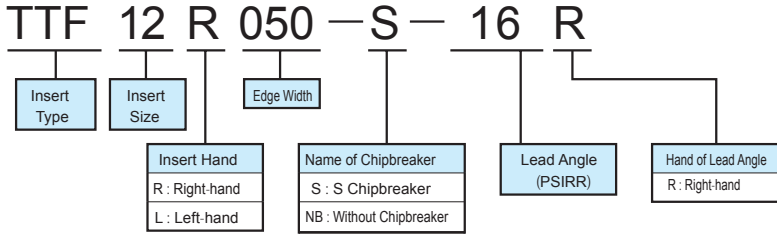

TTF Series Inserts for Parting-off

Model	IC(mm)	T (mm)	d (mm)
TTF12**	8.7	3	5
TTF16**	9.5	4	5

● Good recommendation

Material Recommended

Grade	TG1225
Steel	P ●
Stainless	M ●
Cast Iron	K ●

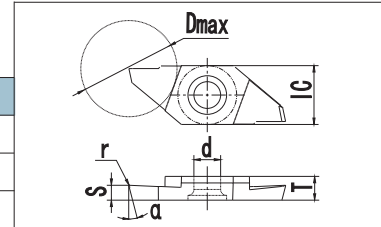



Insert	Order No.		Dimensions (mm)				Toolholders
	Right hand	Left hand	W	α	Dmax	r	
	TTF12R050-S	TTF12L050-S	0.5	0	5	0.05	KTKFR/L1010K-12 KTKFR/L1212K-12 KTKFR/L1212M-12 KTKFR/L1616M-12 KTKFR/L2020M-12 KTKFR/L2525M-12
	TTF12R070-S	TTF12L070-S	0.7	0	8	0.05	
	TTF12R100-S	TTF12L100-S	1.0	0	12	0.08	
	TTF12R150-S	TTF12L150-S	1.5	0	12	0.08	
	TTF12R200-S	TTF12L200-S	2.0	0	12	0.08	
	TTF12R050-S-16R	TTF12L050-S-16R	0.5	16	5	0.05	
	TTF12R070-S-16R	TTF12L070-S-16R	0.7	16	8	0.05	
	TTF12R100-S-16R	TTF12L100-S-16R	1.0	16	12	0.08	
	TTF12R150-S-16R	TTF12L150-S-16R	1.5	16	12	0.08	
TTF12R200-S-16R	TTF12L200-S-16R	2.0	16	12	0.08		
	TTF12R050-NB	TTF12L050-NB	0.5	0	5	0.05	KTKFR/L1010K-16 KTKFR/L1212K-16 KTKFR/L1212M-16 KTKFR/L1616M-16 KTKFR/L2020M-16 KTKFR/L2525M-16
	TTF12R070-NB	TTF12L070-NB	0.7	0	8	0.05	
	TTF12R100-NB	TTF12L100-NB	1.0	0	12	0.08	
	TTF12R150-NB	TTF12L150-NB	1.5	0	12	0.08	
	TTF12R200-NB	TTF12L200-NB	2.0	0	12	0.08	
	TTF12R050-NB-20R	TTF12L050-NB-20R	0.5	20	5	0.05	
	TTF12R070-NB-20R	TTF12L070-NB-20R	0.7	20	8	0.05	
	TTF12R100-NB-20R	TFK12L100-NB-20R	1.0	20	12	0.08	
	TTF12R150-NB-20R	TTF12L150-NB-20R	1.5	20	12	0.08	
TTF12R200-NB-20R	TTF12L200-NB-20R	2.0	20	12	0.08		
	TTF16R100-S	TTF16L100-S	1.0	0	16	0.08	KTKFR/L1010K-16 KTKFR/L1212K-16 KTKFR/L1212M-16 KTKFR/L1616M-16 KTKFR/L2020M-16 KTKFR/L2525M-16
	TTF16R150-S	TTF16L150-S	1.5	0	16	0.10	
	TTF16R200-S	TTF16L200-S	2.0	0	16	0.10	
	TTF16R250-S	TTF16L250-S	2.5	0	16	0.10	
	TTF16R300-S	TTF16L300-S	3.0	0	16	0.15	
	TTF16R100-S-16R	TTF16L100-S-16R	1.0	16	16	0.08	
	TTF16R150-S-16R	TTF16L150-S-16R	1.5	16	16	0.10	
	TTF16R200-S-16R	TTF16L200-S-16R	2.0	16	16	0.10	
	TTF16R250-S-16R	TTF16L250-S-16R	2.5	16	16	0.10	
TTF16R300-S-16R	TTF16L300-S-16R	3.0	16	16	0.15		

Right-hand Insert for Right-hand Toolholder
Left-hand Insert for Left-hand Toolholder

Insert
External Toolholder
Internal Toolholder
Threading
Parting, Grooving
Miniature Tool

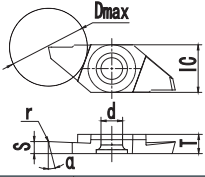
Turnline TTF Series
Parting

Model	IC (mm)	T (mm)	d (mm)	● Good recommendation			
				Material Recommended	Grade	TG1225	
TTF12**	8.7	3	5		Steel	P ●	
TTF16**	9.5	4	5		Stainless	M ●	
					Cast Iron	K ●	

Insert	Order No.		Dimensions (mm)				Toolholders
	Right hand	Left hand	W	α	Dmax	r	
	TTF16R100-NB	TTF16L100-NB	1.0	0	16	0.08	KTKFR/L1010K-16 KTKFR/L1212K-16 KTKFR/L1212M-16 KTKFR/L1616M-16 KTKFR/L2020M-16 KTKFR/L2525M-16
	TTF16R150-NB	TTF16L150-NB	1.5	0	16	0.10	
	TTF16R200-NB	TTF16L200-NB	2.0	0	16	0.10	
	TTF16R250-NB	TTF16L250-NB	2.5	0	16	0.10	
	TTF16R300-NB	TTF16L300-NB	3.0	0	16	0.15	
	TTF16R100-NB-20R	TTF16L100-NB-20R	1.0	20	16	0.08	
	TTF16R150-NB-20R	TTF16L150-NB-20R	1.5	20	16	0.10	
	TTF16R200-NB-20R	TTF16L200-NB-20R	2.0	20	16	0.10	
	TTF16R250-NB-20R	TTF16L250-NB-20R	2.5	20	16	0.10	
	TTF16R300-NB-20R	TTF16L300-NB-20R	3.0	20	16	0.15	

Right-hand Insert for Right-hand Toolholder
Left-hand Insert for Left-hand Toolholder

TTF Series Toolholders for Parting-off

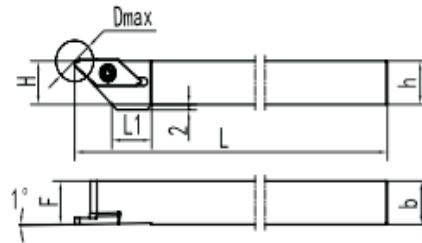

Order No.	Insert	Dimensions (mm)							Insert Screw	Torx Key
		h	b	H	F	L	Dmax	L1		
KTKFR1010K-12	TTF12R**	10	10	10	10	125	12	15	L60M410	T15
KTKFR1212K-12		12	12	12	12					
KTKFR1212M-12		12	12	12	12					
KTKFR1616M-12		16	16	16	16					
KTKFR2020M-12		20	20	20	20					
KTKFR2525M-12		25	25	25	25					
KTKFR1010K-16	TTF16R**	10	10	10	10	125	16	20	L60M410	T15
KTKFR1212K-16		12	12	12	12					
KTKFR1212M-16		12	12	12	12					
KTKFR1616M-16		16	16	16	16					
KTKFR2020M-16		20	20	20	20					
KTKFR2525M-16		25	25	25	25					
KTKFL1010K-12	TTF12L**	10	10	10	10	125	12	15	L60M410	T15
KTKFL1212K-12		12	12	12	12					
KTKFL1212M-12		12	12	12	12					
KTKFL1616M-12		16	16	16	16					
KTKFL2020M-12		20	20	20	20					
KTKFL2525M-12		25	25	25	25					
KTKFL1010K-16	TTF16L**	10	10	10	10	125	16	20	L60M410	T15
KTKFL1212K-16		12	12	12	12					
KTKFL1212M-16		12	12	12	12					
KTKFL1616M-16		16	16	16	16					
KTKFL2020M-16		20	20	20	20					
KTKFL2525M-16		25	25	25	25					

Turnline TTF Series
Standard Cutting Conditions

TTF Series Standard Cutting Conditions

ISO	Workpiece Material	Vc(m/min)	TTF12					TTF16				
			Edge Width (mm)					Edge Width (mm)				
			0.5	0.7	1.0	1.5	2.0	1.0	1.5	2.0	2.5	3.0
			f(mm/min)					f(mm/min)				
P	Carbon Steel	70-150	0.01-0.02	0.01-0.03	0.01-0.04	0.01-0.04	0.01-0.04	0.01-0.06	0.02-0.07	0.02-0.07	0.02-0.07	0.02-0.08
	Alloy Steel	70-150	0.01-0.02	0.01-0.03	0.01-0.04	0.01-0.04	0.01-0.04	0.01-0.06	0.02-0.07	0.02-0.07	0.02-0.07	0.02-0.08
M	Stainless Steel	60-120	0.01-0.02	0.01-0.02	0.01-0.02	0.01-0.02	0.01-0.02	0.01-0.03	0.01-0.04	0.01-0.04	0.01-0.04	0.01-0.05
K	Cast Iron	50-100	0.01-0.03	0.01-0.04	0.01-0.05	0.01-0.05	0.01-0.05	0.01-0.07	0.02-0.08	0.02-0.08	0.02-0.08	0.02-0.08

Insert
External Toolholder
Internal Toolholder
Threading
Parting, Grooving
Miniature Tool

Turnline TTS Series
Grooving & Parting-off

TTS27 Series for Inserts

Insert	Order No.	Dimensions (mm)														Toolholder
		W	r	Tmax	Dmax											
			T≤3.0	T≤3.5	T≤4.0	T≤4.5	T≤5.0	T≤5.5	T≤5.7	T≤6.0	T≤6.2	T≤6.4				
	TTS27-1.00-0.10	1.0	0.1	3.5	∞	600	-	-	-	-	-	-	-	-	-	TQHR...-27
	TTS27-1.50-0.20	1.5	0.2	5.7	∞	600	280	180	130	50	35	-	-	-		
	TTS27-2.00-0.20	2.0	0.2	6.4	∞	600	280	180	130	105	85	60	50	30		
	TTS27-2.50-0.20	2.5	0.2	5.7	∞	600	280	180	130	50	35	-	-	-		
	TTS27-3.00-0.20	3.0	0.2	6.4	∞	600	280	180	135	105	95	85	78	55		

● Good recommendation		
Material Recommended	Grade	TG1230
	Steel	P ●
	Stainless	M ●
	Cast Iron	K ●

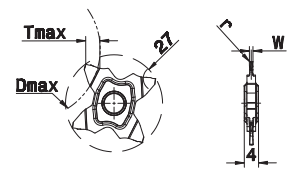

TTS27 Series for Toolholders

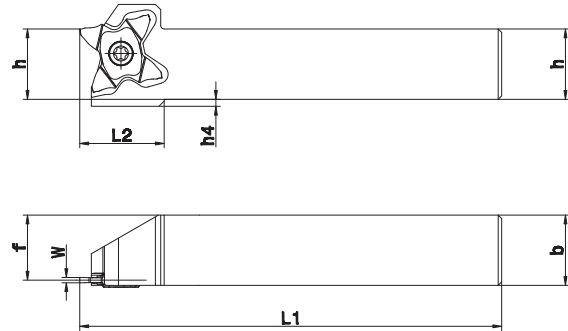

Order No.	Insert	Dimensions (mm)							Insert Screw	Torx Key
		h	b	W	f	l1	l2	h4		
TQHR10-27	TTS27-**	10	10	0.5 ≤ W ≤ 5.3	8.5	120	24	9	BFTX5012	TRX20
TQHR12-27		12	12	0.5 ≤ W ≤ 5.3	10.5	120	24	8		
TQHR16-27		16	16	0.5 ≤ W ≤ 5.3	14.5	120	24	6		
TQHR20-27		20	20	0.5 ≤ W ≤ 5.3	18.5	120	24	2		
TQHR25-27		25	25	0.5 ≤ W ≤ 5.3	23.5	135	-	-		

TTS27 Series Standard Cutting Conditions

ISO	Workpiece Material	Vc(m/min)	
P	Non-Alloy steel	<0.25%C	110-200
		0.25%C- 0.55%C	70-180
		≥ 0.55%C	60-180
	Low Alloy Steel	80-180	
	High Alloy Steel	60-140	
M	Martensitic Stainless Steel	120-180	
	Austenitic Stainless Steel	70-140	
K	Grey Cast Iron	70-180	
	Ductile Cast Iron	60-130	
N	Cast Aluminum Alloy	200-400	
	Aluminum Alloy	300-700	
	Copper Alloy	80-300	
S	Heat-resistance Alloy	10-50	
	Titanium Alloy	25-60	
H	Hardened Alloy	45-50 HRC	40-50
		51-55 HRC	30-50

MT SERIES

Solid Boring Bar for Boring

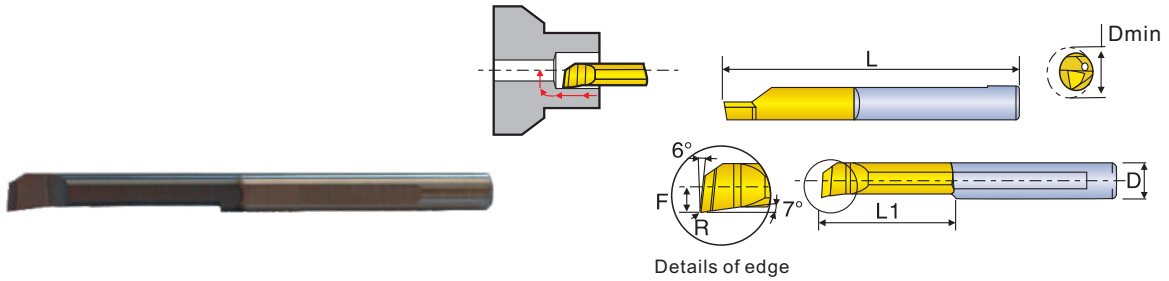

Order No.	Dimensions (mm)						Sleeve No.
	D	L	L1	R	F	Dmin	
MTR1R0.05L4	3	40	4	0.05	0.5	1.0	NC1603-100-2N
MTR1.5R0.1L6	3	40	6	0.10	0.7	1.5	
MTR2R0.05L10	3	40	10	0.05	0.8	2.1	
MTR2R0.15L5	3	40	5	0.15	0.8	2.1	
MTR2R0.15L10	3	40	10	0.15	0.8	2.1	
MTR2R0.15L15	3	40	15	0.15	0.8	2.1	
MTR2R0.15L20	3	40	20	0.15	0.8	2.1	
MTR3R0.05L10	3	40	10	0.05	1.3	3.1	
MTR3R0.05L15	3	40	15	0.05	1.3	3.1	
MTR3R0.1L10	3	40	10	0.10	1.3	3.1	
MTR3R0.1L15	3	40	15	0.10	1.3	3.1	
MTR3R0.2L10	3	40	10	0.20	1.3	2.1	
MTR3R0.2L15	3	40	15	0.20	1.3	3.1	
MTR3R0.2L20	3	40	20	0.20	1.3	3.1	
MTR4R0.05L15	4	50	15	0.05	1.7	4.1	NC. . 04-100-2N
MTR4R0.1L15	4	50	15	0.10	1.7	4.1	
MTR4R0.1L22	4	50	22	0.10	1.7	4.1	
MTR4R0.2L10	4	50	10	0.20	1.7	4.1	
MTR4R0.2L15	4	50	15	0.20	1.7	4.1	
MTR4R0.2L22	4	50	22	0.20	1.7	4.1	
MTR4R0.2L30	4	65	30	0.20	1.7	4.1	NC. . 05-100-2N
MTR5R0.05L15	5	50	15	0.05	2.1	5.1	
MTR5R0.1L22	5	50	22	0.10	2.1	5.1	
MTR5R0.2L10	5	50	10	0.20	2.1	5.1	
MTR5R0.2L15	5	50	15	0.20	2.1	5.1	
MTR5R0.2L22	5	50	22	0.20	2.1	5.1	
MTR5R0.2L30	5	65	30	0.20	2.1	5.1	NC. . 05-100-2N
MTR5R0.2L35	5	65	35	0.20	2.1	5.1	

Insert

External Toolholder

Internal Toolholder

Threading

Parting, Grooving

Miniature Tool

MT SERIES Solid Boring Bar for Boring

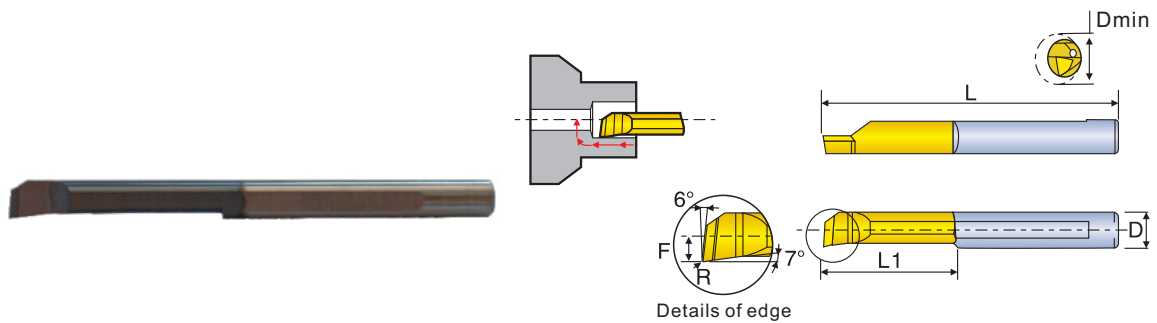

Order No.	Dimensions (mm)						Sleeve No.
	D	L	L1	R	F	Dmin	
MTR6R0. 05L15	6	50	15	0.05	2.8	6.1	NC. .06-100-2N
MTR6R0. 1L22	6	50	22	0.10	2.8	6.1	
MTR6R0. 2L15	6	50	15	0.20	2.8	6.1	
MTR6R0. 2L22	6	50	22	0.20	2.8	6.1	
MTR6R0. 2L30	6	65	30	0.20	2.8	6.1	NC. .07-100-2N
MTR6R0. 2L40	6	65	40	0.20	2.8	6.1	
MTR7R0. 2L30	7	65	30	0.20	3.3	7.1	
MTR7R0. 2L35	7	65	35	0.20	3.3	7.1	
MTR7R0. 2L42	7	80	42	0.20	3.3	7.1	NC. .08-100-2N
MTR7R0. 2L49	7	80	49	0.20	3.3	7.1	
MTR8R0. 2L40	8	80	40	0.20	3.8	8.1	
MTR10R0. 2L35	10	65	35	0.20	4.8	10.1	NC2010-100-2N
MTR10R0. 2L50	10	80	50	0.20	4.8	10.1	
MTL2R0. 15L10	3	40	10	0.15	0.8	2.1	NC1603-100-2N
MTL3R0. 2L15	3	40	15	0.20	1.3	3.1	
MTL4R0. 2L22	4	50	22	0.20	1.7	4.1	NC. .04-100-2N
MTL5R0. 2L22	5	50	22	0.20	2.1	5.1	NC. .05-100-2N
MTL6R0. 2L22	6	50	22	0.20	2.8	6.1	NC. .06-100-2N
MTL7R0. 2L30	7	65	30	0.20	3.3	7.1	NC. .07-100-2N

MTR SERIES Solid Boring Bar for Boring (Internal Coolant)

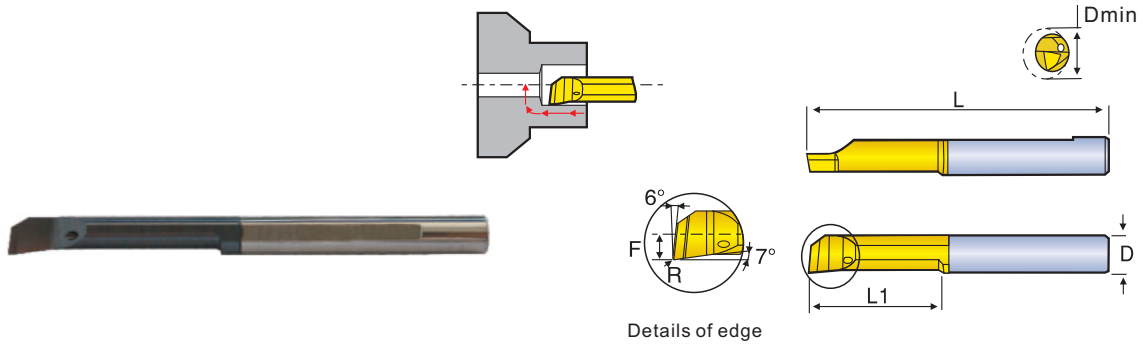

Order No.	Dimensions (mm)						Sleeve No.
	D	L	L1	R	F	Dmin	
MTR4R0. 2L15-N	4	50	15	0.2	1.7	4.1	NC..04-100-2N
MTR4R0. 2L22-N	4	50	22	0.2	1.7	4.1	
MTR5R0. 2L15-N	5	50	15	0.2	2.1	5.1	NC..05-100-2N
MTR5R0. 2L22-N	5	50	22	0.2	2.1	5.1	
MTR6R0. 2L22-N	6	50	22	0.1	2.8	6.1	NC..06-100-2N

MPR SERIES Solid Boring Bar for Profiling

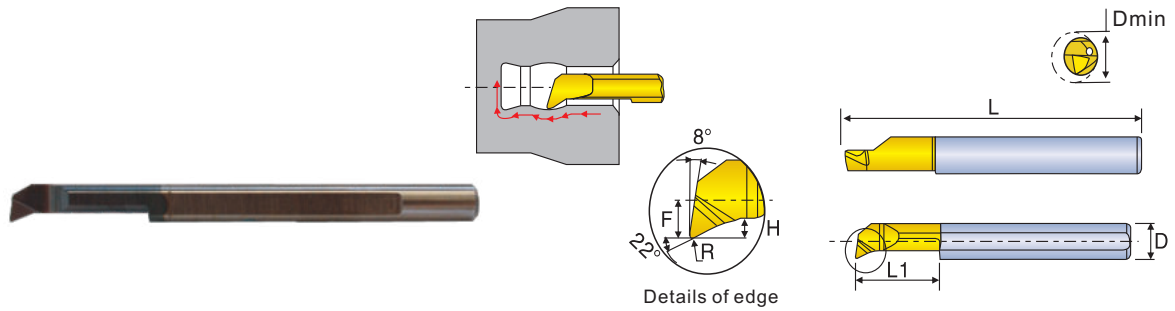

Order No.	Dimensions (mm)							Sleeve No.
	D	L	L1	R	H	F	Dmin	
MPR1R0. 05L4	3	40	4	0.05	0.2	0.5	1.0	NC1603-100-2N
MPR1. 5R0. 1L6	3	40	6	0.10	0.3	0.7	1.5	
MPR2R0. 15L10	3	40	10	0.15	0.5	0.8	2.1	
MPR3R0. 2L10	3	40	10	0.20	0.7	1.3	3.1	
MPR3R0. 2L15	3	40	15	0.20	0.7	1.3	3.1	
MPR4R0. 2L15	4	50	15	0.20	0.8	1.7	4.1	NC..04-100-2N
MPR4R0. 2L22	4	50	22	0.20	0.8	1.7	4.1	
MPR5R0. 2L22	5	50	22	0.20	1.2	2.1	5.1	NC..05-100-2N
MPR5R0. 2L30	5	65	30	0.20	1.2	2.1	5.1	
MPR6R0. 2L22	6	50	22	0.20	1.4	2.8	6.1	NC..06-100-2N
MPR6R0. 2L30	6	65	30	0.20	1.4	2.8	6.1	

MG SERIES

Solid Boring Bar for Internal Grooving

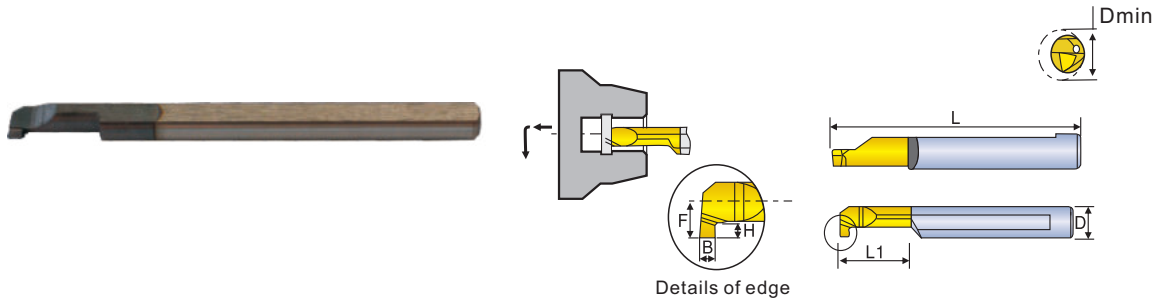

Order No.	Dimensions (mm)							Sleeve No.
	B	H	D	L	L1	F	Dmin	
MGR2B0. 5L6	0.5	0.4	3	40	6	0.8	2.1	NC1603-100-2N
MGR3B0. 5L10	0.5	0.5	3	40	10	1.3	3.1	
MGR3B0. 7L10	0.7	0.6	3	40	10	1.3	3.1	
MGR3B1. 0L10	1.0	0.7	3	40	10	1.3	3.1	
MGR4B1. 0L10	1.0	1.0	4	50	10	1.7	4.1	NC. . 04-100-2N
MGR4B1. 5L10	1.5	1.0	4	50	10	1.7	4.1	
MGR4B1. 0L15	1.0	1.0	4	50	15	1.7	4.1	
MGR4B1. 5L15	1.5	1.0	4	50	15	1.7	4.1	
MGR5B1. 0L15	1.0	1.2	5	50	15	2.3	5.1	NC. . 05-100-2N
MGR5B1. 5L15	1.5	1.2	5	50	15	2.3	5.1	
MGR5B2. 0L15	2.0	1.2	5	50	15	2.3	5.1	
MGR5B1. 0L22	1.0	1.2	5	50	22	2.3	5.1	
MGR5B1. 5L22	1.5	1.2	5	50	22	2.3	5.1	
MGR5B2. 0L22	2.0	1.2	5	50	22	2.3	5.1	
MGR6B1. 0L15	1.0	1.8	6	50	15	2.8	6.1	NC. . 06-100-2N
MGR6B1. 5L15	1.5	1.8	6	50	15	2.8	6.1	
MGR6B2. 0L15	2.0	1.8	6	50	15	2.8	6.1	
MGR6B1. 0L22	1.0	1.8	6	50	22	2.8	6.1	
MGR6B1. 5L22	1.5	1.8	6	50	22	2.8	6.1	
MGR6B2. 0L22	2.0	1.8	6	50	22	2.8	6.1	
MGR6B1. 0L30	1.0	1.8	6	65	30	2.8	6.1	
MGR6B1. 5L30	1.5	1.8	6	65	30	2.8	6.1	
MGR6B2. 0L30	2.0	1.8	6	65	30	2.8	6.1	
MGR6B1. 0L17-2.0	1.0	2.0	6	50	17	2.8	6.1	
MGR6B1. 5L17-2.0	1.5	2.0	6	50	17	2.8	6.1	
MGR6B2. 0L17-2.0	2.0	2.0	6	50	17	2.8	6.1	

MG SERIES Solid Boring Bar for Internal Grooving

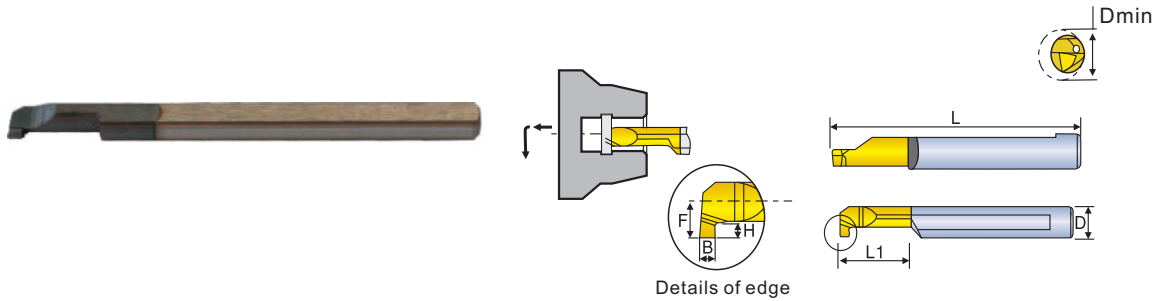

Order No.	Dimensions (mm)							Sleeve No.
	B	H	D	L	L1	F	Dmin	
MGR7B1. 0L22	1.0	2.5	7	65	22	3.3	7.1	NC. . 07-100-2N
MGR7B1. 5L22	1.5	2.5	7	65	22	3.3	7.1	
MGR7B2. 0L22	2.0	2.5	7	65	22	3.3	7.1	
MGR7B1. 0L30	1.0	2.5	7	65	30	3.3	7.1	
MGR7B1. 5L30	1.5	2.5	7	65	30	3.3	7.1	
MGR7B2. 0L30	2.0	2.5	7	65	30	3.3	7.1	
MGR8B1. 0L22	1.0	2.6	8	65	22	3.8	8.1	NC. . 08-100-2N
MGR8B1. 5L22	1.5	2.6	8	65	22	3.8	8.1	
MGR8B2. 0L22	2.0	2.6	8	65	22	3.8	8.1	
MGR8B1. 5L22X	1.5	3.1	8	65	22	3.8	8.1	
MGR8B2. 0L22X	2.0	3.1	8	65	22	3.8	8.1	
MGR8B2. 0L30X	2.0	3.1	8	65	30	3.8	8.1	
MGR8B2. 0L40X	2.0	3.1	8	80	40	3.8	8.1	
MGL3B0. 7L10	0.7	0.6	3	40	10	1.3	3.1	NC1603-100-2N
MGL4B1. 5L10	1.5	1.0	4	50	10	1.7	4.1	NC. . 04-100-2N
MGL5B2. 0L15	2.0	1.2	5	50	15	2.3	5.1	NC. . 05-100-2N
MGL6B2. 0L15	2.0	1.8	6	50	15	2.8	6.1	NC. . 06-100-2N
MGL6B2. 0L22	2.0	1.8	6	50	22	2.3	6.1	
MGL7B2. 0L30	2.0	2.5	7	65	30	2.8	7.1	NC. . 07-100-2N

Insert

External Toolholder

Internal Toolholder

Threading

Parting, Grooving

Miniature Tool

MGR SERIES

Solid Boring Bar for Internal Grooving (Internal Coolant)

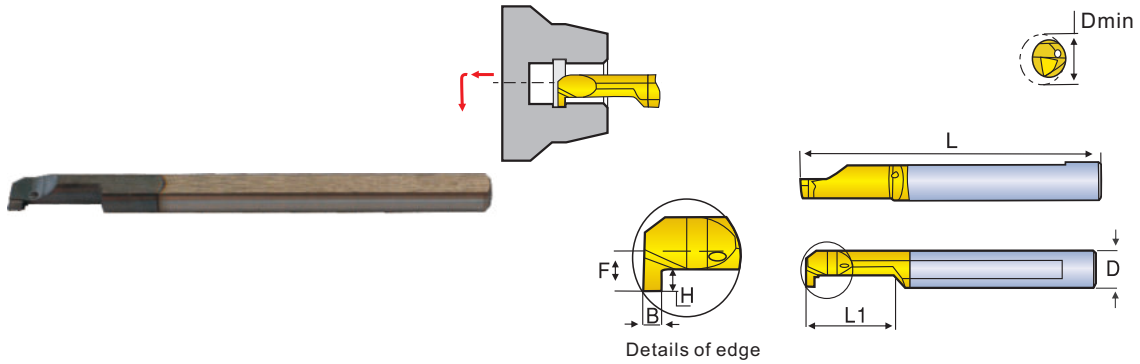

Order No.	Dimensions (mm)							Sleeve No.
	B	H	D	L	L1	F	Dmin	
MGR4B1.0L10-N	1.0	1.0	4	50	10	1.7	4.1	NC. .04-100-2N
MGR4B1.5L10-N	1.5	1.0	4	50	10	1.7	4.1	
MGR5B1.0L15-N	1.0	1.2	5	50	15	2.3	5.1	NC. .05-100-2N
MGR5B1.5L15-N	1.5	1.2	5	50	15	2.3	5.1	
MGR5B2.0L15-N	2.0	1.2	5	50	15	2.3	5.1	NC. .06-100-2N
MGR6B1.0L15-N	1.0	1.8	6	50	15	2.8	6.1	
MGR6B1.5L15-N	1.5	1.8	6	50	15	2.8	6.1	
MGR6B2.0L15-N	2.0	1.8	6	50	15	2.8	6.1	

MKR SERIES

Solid Boring Bar for Profiling

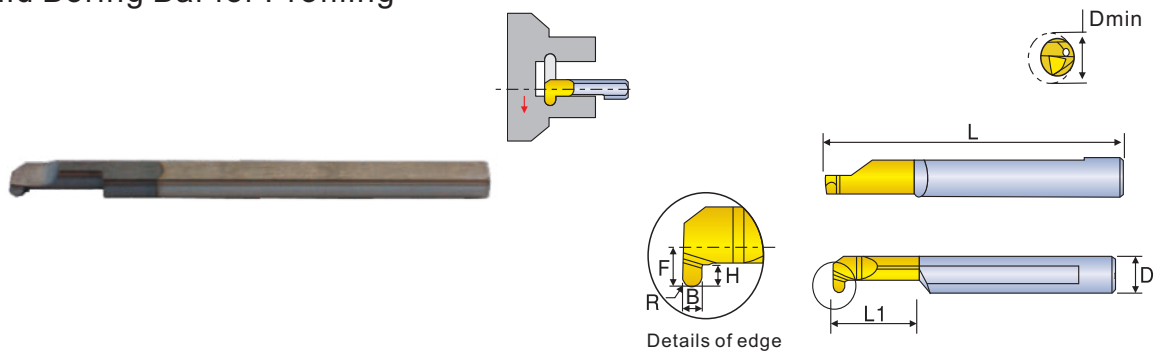

Order No.	Dimensions (mm)								Sleeve No.
	B	R	H	D	L	L1	F	Dmin	
MKR4R0.5L10	1.0	0.50	1.0	4	50	10	1.7	4.1	NC. .04-100-2N
MKR4R0.75L10	1.5	0.75	1.0	4	50	10	1.7	4.1	

MKR SERIES Solid Boring Bar for Profiling

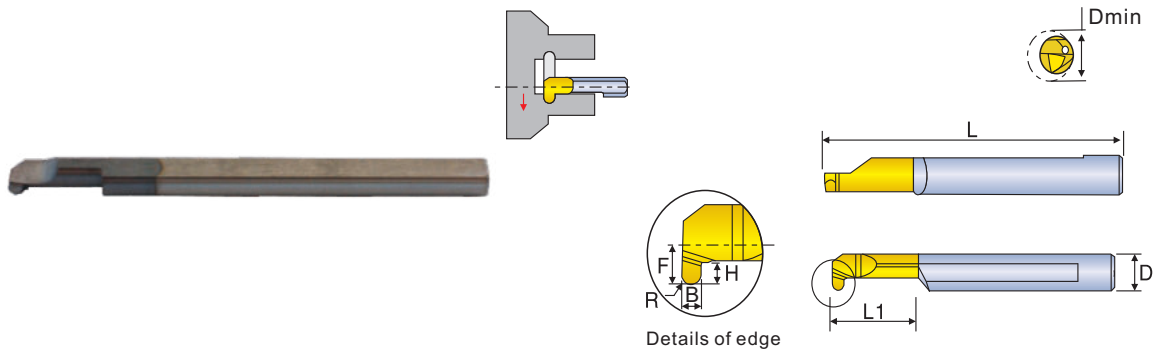

Order No.	Dimensions (mm)								Sleeve No.
	B	R	H	D	L	L1	F	Dmin	
MKR5R0.5L15	1.0	0.50	1.2	5	50	15	2.3	5.1	NC. .05-100-2N
MKR5R0.75L15	1.5	0.75	1.2	5	50	15	2.3	5.1	
MKR5R1.0L15	2.0	1.00	1.2	5	50	15	2.3	5.1	
MKR6R0.5L15	1.0	0.50	1.6	6	50	15	2.8	6.1	NC. .06-100-2N
MKR6R0.75L15	1.5	0.75	1.6	6	50	15	2.8	6.1	
MKR6R1.0L15	2.0	1.00	1.6	6	50	15	2.8	6.1	

MFR SERIES Solid Boring Bar for Face Grooving

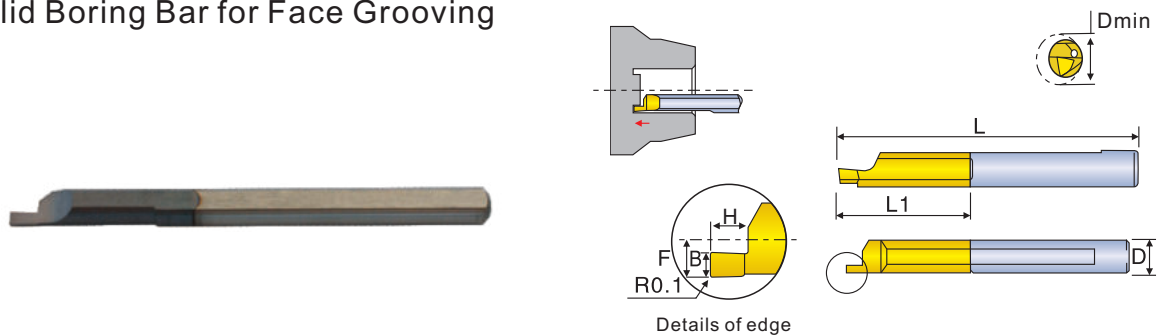

Order No.	Dimensions (mm)							Sleeve No.
	B	H	D	L	L1	F	Dmin	
MFR4B1.0L15	1.0	1.5	4	50	15	1.95	5	NC. .04-100-2N
MFR4B1.5L15	1.5	2.8	4	50	15	1.95	5	
MFR5B1.0L22	1.0	1.5	5	50	22	2.45	6	NC. .05-100-2N
MFR5B1.5L22	1.5	2.5	5	50	22	2.45	6	
MFR5B2.0L22	2.0	3.8	5	50	22	2.45	6	

MFR SERIES Solid Boring Bar for Face Grooving

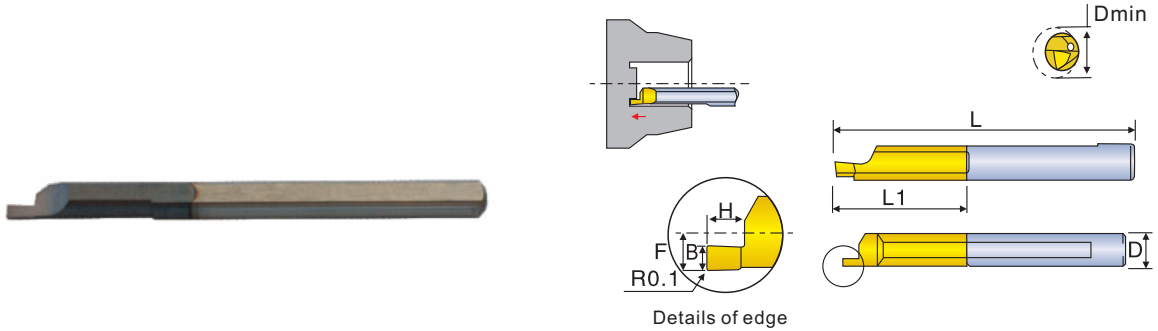

Order No.	Dimensions (mm)							Sleeve No.
	B	H	D	L	L1	F	Dmin	
MFR6B1. 0L22	1.0	1.5	6	50	22	2.95	8	NC. . 06-100-2N
MFR6B1. 5L22	1.5	2.5	6	50	22	2.95	8	
MFR6B2. 0L22	2.0	3.0	6	50	22	2.95	8	
MFR6B3. 0L30	3.0	6.0	6	65	30	2.95	8	

MFL SERIES Solid Boring Bar for Face Grooving

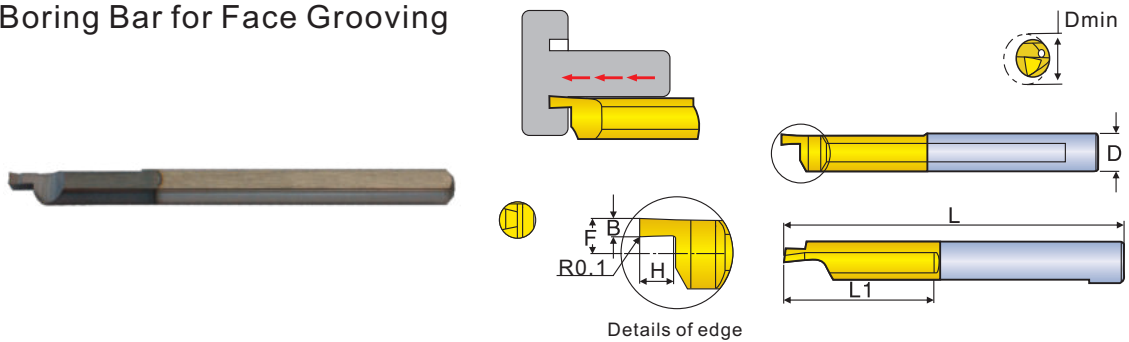

Order No.	Dimensions (mm)							Sleeve No.
	B	H	D	L	L1	F	Dmin	
MFL4B1. 0L15	1.0	1.5	4	50	15	1.75	5	NC. . 04-100-2N
MFL4B1. 5L15	1.5	2.8	4	50	15	1.75	5	
MFL5B1. 0L22	1.0	1.5	5	50	22	2.25	6	NC. . 05-100-2N
MFL5B1. 5L22	1.5	2.5	5	50	22	2.25	6	
MFL5B2. 0L22	2.0	3.8	5	50	22	2.25	6	NC. . 06-100-2N
MFL6B1. 0L22	1.0	1.5	6	50	22	2.75	8	
MFL6B1. 5L22	1.5	2.5	6	50	22	2.75	8	
MFL6B2. 0L22	2.0	3.0	6	50	22	2.75	8	
MFL6B3. 0L30	3.0	6.0	6	65	30	2.75	8	

MI SERIES Solid Boring Bar for Threading

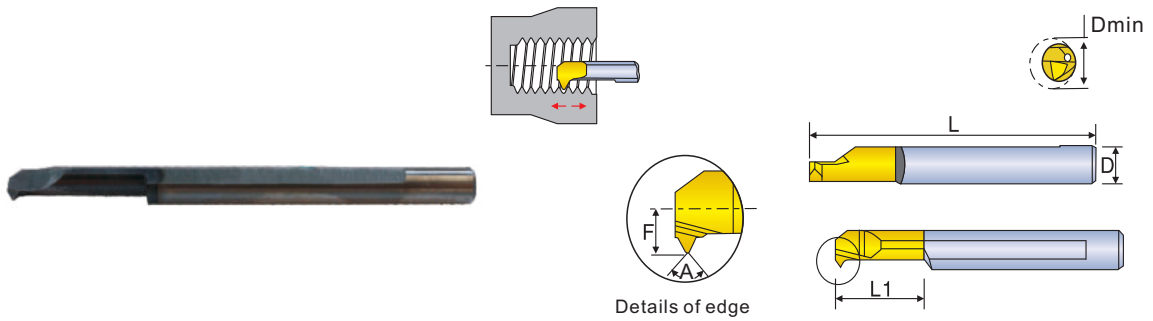

Order No.	Dimensions (mm)								Sleeve No.
	D	L	L1	Thread angle	Pitch		F	Dmin	
				A	mm	TPI			
MIR2L8A60	3	40	8	60	0.45-0.70	56-32	1.0	2.1	NC1603-100-2N
MIR3L15A60	3	40	15	60	0.50-1.00	48-24	1.4	3.2	
MIR4L15A60	4	50	15	60	0.50-1.00	48-24	1.8	4.1	NC..04-100-2N
MIR5L15A60	5	50	15	60	0.50-1.25	48-20	2.3	5.1	NC..05-100-2N
MIR5L22A60	5	50	22	60	1.00-1.25	24-20	2.3	5.1	
MIR6L15A60	6	50	15	60	0.50-1.50	48-16	2.6	6.0	NC..06-100-2N
MIR6L22A60	6	50	22	60	0.50-1.50	48-16	2.6	6.0	
MIR8L22A60	8	65	22	60	1.00-2.00	24-13	3.6	8.0	NC..08-100-2N
MIR3L15A55	3	40	15	55	0.50-1.00	48-24	1.4	3.2	NC1603-100-2N
MIR4L15A55	4	50	15	55	0.50-1.00	48-24	1.8	4.1	NC..04-100-2N
MIR5L15A55	5	50	15	55	0.50-1.25	48-20	2.3	5.1	NC..05-100-2N
MIR6L15A55	6	50	15	55	0.50-1.50	48-16	2.6	6.0	NC..06-100-2N
MIL3L15A60	3	40	15	60	0.50-1.00	32-24	1.4	3.2	NC1603-100-2N
MIL4L15A60	4	50	15	60	0.50-1.00	48-24	1.8	4.1	NC..04-100-2N
MIL5L15A60	5	50	15	60	0.50-1.25	48-20	2.3	5.1	NC..05-100-2N
MIL6L15A60	6	50	15	60	0.50-1.50	48-16	2.6	6.0	NC..06-100-2N
MIL3L15A55	3	40	15	55	0.50-1.00	48-24	1.4	3.2	NC1603-100-2N
MIL4L15A55	4	50	15	55	0.50-1.00	48-24	1.8	4.1	NC..04-100-2N
MIL5L15A55	5	50	15	55	0.50-1.25	48-20	2.3	5.1	NC..05-100-2N
MIL6L15A55	6	50	15	55	0.50-1.50	48-16	2.6	6.0	NC..06-100-2N

Insert

External Toolholder

Internal Toolholder

Threading

Parting, Grooving

Miniature Tool

MIR SERIES

Solid Boring Bar for Threading (Internal Coolant)

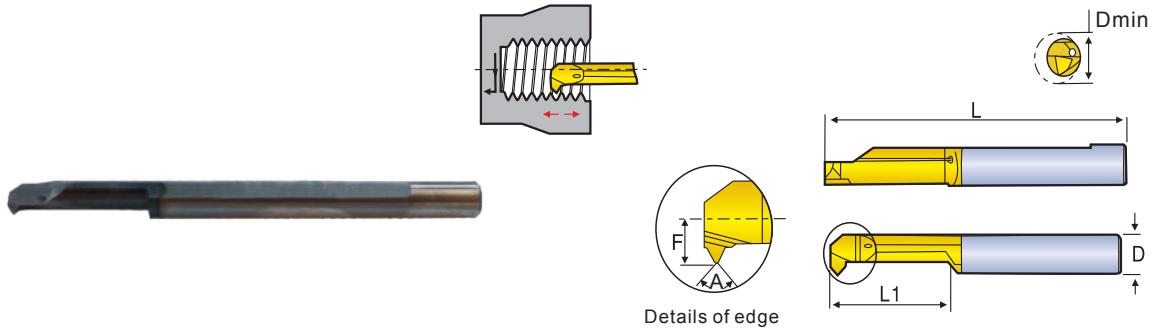

Order No.	Dimensions (mm)								Sleeve No.
	D	L	L1	Thread angle	Pitch		F	Dmin	
				A	mm	TPI			
MIR4L15A60-N	4	50	15	60	0.80-1.00	32-24	1.8	4.1	NC..04-100-2N
MIR5L15A60-N	5	50	15	60	1.00-1.25	24-20	2.3	5.1	NC..05-100-2N
MIR6L15A60-N	6	50	15	60	1.00-1.50	24-16	2.6	6.0	NC..06-100-2N
MIR6L22A60-N	8	50	22	60	1.00-1.50	24-16	2.6	6.0	

Sleeve for Coolant Supply

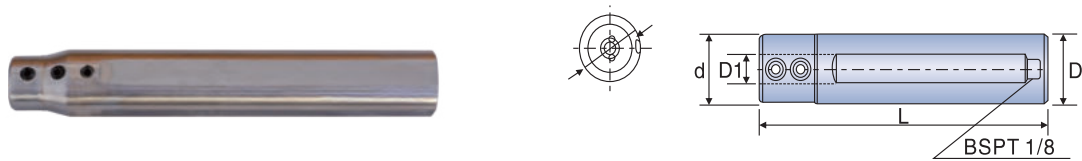

Order No.	Dimensions (mm)				Wrench	Screw
	D1	L	D	d		
NC1603-100-2N	3	100	16	12.0	WT15	S34
NC1604-100-2N	4	100	16	13.0	WT20	S44
NC1605-100-2N	5	100	16	14.7	WT25	S44
NC1606-100-2N	6	100	16	15.0	WT25	S54
NC1608-100-2N	8	100	16	15.7	WT30	S66
NC2004-100-2N	4	100	20	13.0	WT20	S44
NC2005-100-2N	5	100	20	16.0	WT25	S44
NC2006-100-2N	6	100	20	17.0	WT30	S55
NC2007-100-2N	7	100	20	17.5	WT30	S66
NC2008-100-2N	8	100	20	19.0	WT30	S66
NC2010-100-2N	10	100	20	19.7	WT30	S66
NC2012-100-2N	12	100	20	19.7	WT30	S66

Standard Cutting Conditions of Boring

ISO	Workpiece material		Vc (m/min)	f (mm/min)
P	Non-Alloy steel	<0.25%C	50-120	0.05
		0.25%C- 0.55%C	40-100	0.04
		≥0.55%C	30-80	0.03
	Low Alloy Steel		30-70	0.04
	High Alloy Steel		25-50	0.03
M	Martensitic Stainless Steel		40-100	0.04
	Austenitic Stainless Steel		40-90	0.04
K	Grey Cast Iron		40-70	0.02
	Ductile Cast Iron		50-80	0.02
N	Cast Aluminum Alloy		100-300	0.03
	Aluminum Alloy		60-150	0.03
	Copper Alloy		100-150	0.03
S	Heat-resistance Alloy		10-45	0.02
	Titanium Alloy		40-60	0.02
H	Hardened Alloy	45-50 HRC	20-40	0.01
		51-55 HRC	20-35	0.01

Standard Cutting Conditions of Grooving

ISO	Workpiece material		Vc (m/min)	f (mm/min)
P	Non-Alloy steel	<0.25%C	50-120	0.03
		0.25%C- 0.55%C	40-100	0.02
		≥0.55%C	30-80	0.01
	Low Alloy Steel		30-70	0.02
	High Alloy Steel		25-50	0.01
M	Martensitic Stainless Steel		40-100	0.01
	Austenitic Stainless Steel		40-90	0.01
K	Grey Cast Iron		40-70	0.02
	Ductile Cast Iron		50-80	0.01
N	Cast Aluminum Alloy		100-300	0.03
	Aluminum Alloy		60-150	0.03
	Copper Alloy		100-150	0.03
S	Heat-resistance Alloy		10-45	0.01
	Titanium Alloy		40-60	0.01
H	Hardened Alloy	45-50 HRC	20-40	0.01
		51-55 HRC	20-35	0.01

Insert

External Toolholder

Internal Toolholder

Threading

Parting, Grooving

Miniature Tool

Standard Cutting Conditions of Threading

ISO	Workpiece material		Vc(m/min)
P	Non-Alloy steel	<0.25%C	50-120
		0.25%C- 0.55%C	40-100
		≥0.55%C	30-80
	Low Alloy Steel		30-70
	High Alloy Steel		25-50
M	Martensitic Stainless Steel		40-100
	Austenitic Stainless Steel		40-90
K	Grey Cast Iron		40-70
	Ductile Cast Iron		50-80
N	Cast Aluminum Alloy		100-300
	Aluminum Alloy		60-150
	Copper Alloy		100-150
S	Heat-resistance Alloy		10-45
	Titanium Alloy		40-60
H	Hardened Alloy	45-50 HRC	20-40
		51-55 HRC	20-35

Standard Cutting Conditions of Face Grooving

ISO	Workpiece material		Vc(m/min)	f(mm/min)
P	Non-Alloy steel	<0.25%C	40-140	0.01-0.05
		0.25%C- 0.55%C		
		≥0.55%C		
	Low Alloy Steel			
High Alloy Steel				
M	Martensitic Stainless Steel		40-140	0.01-0.05
	Austenitic Stainless Steel			
K	Grey Cast Iron		30-130	0.01-0.05
	Ductile Cast Iron			
N	Cast Aluminum Alloy		90-120	0.01-0.05
	Aluminum Alloy			
	Copper Alloy			
S	Heat-resistance Alloy		30-100	0.01-0.05
	Titanium Alloy			

Modular Small Hole Cutter for Inserts

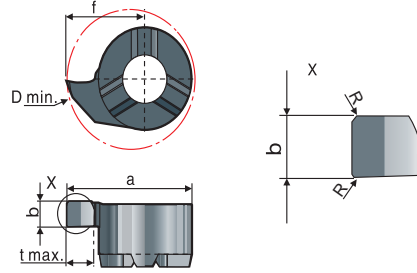

Order No.	Dimensions (mm)					
	b	t max	a	f	R	Dmin
MB-05GR075-1.4D07	0.75	1.4	6.8	4.3	0.05	7.0
MB-05GR100-1.4D07	1.00	1.4	6.8	4.3	0.05	7.0
MB-05GR150-1.4D07	1.50	1.4	6.8	4.3	0.10	7.0
MB-05GR200-1.4D07	2.00	1.4	6.8	4.3	0.20	7.0
MB-05GR100-2.3D08	1.00	2.3	7.8	5.2	0.05	8.0
MB-05GR150-2.3D08	1.50	2.3	7.8	5.2	0.10	8.0
MB-05GR200-2.3D08	2.00	2.3	7.8	5.2	0.20	8.0
MB-05GR100-2.8D09	1.00	2.8	8.3	5.8	0.05	8.8
MB-05GR150-2.8D09	1.50	2.8	8.3	5.8	0.10	8.8
MB-05GR200-2.8D09	2.00	2.8	8.3	5.8	0.20	8.8
MB-07GR075-2.0D10	0.75	2.0	9.5	6.0	0.05	10.0
MB-07GR100-2.0D10	1.00	2.0	9.5	6.0	0.05	10.0
MB-07GR150-2.0D10	1.50	2.0	9.5	6.0	0.05	10.0
MB-07GR200-2.0D10	2.00	2.0	9.5	6.0	0.20	10.0
MB-07GR300-2.0D10	3.00	2.0	9.5	6.0	0.20	10.0
MB-07GR100-3.0D11	1.00	3.0	10.5	7.0	0.05	11.0
MB-07GR150-3.0D11	1.50	3.0	10.5	7.0	0.10	11.0
MB-07GR200-3.0D11	2.00	3.0	10.5	7.0	0.20	11.0
MB-07GR300-3.0D11	3.00	3.0	10.5	7.0	0.20	11.0
MB-07GR100-3.5D12	1.00	3.5	11.5	7.5	0.05	12.0
MB-09GR150-4.0D14	1.50	4.0	13.5	9.0	0.10	14.0
MB-09GR200-4.0D14	2.00	4.0	13.5	9.0	0.20	14.0
MB-09GR250-4.0D14	2.50	4.0	13.5	9.0	0.20	14.0
MB-09GR150-5.5D16	1.50	5.5	15.0	10.3	0.10	16.0
MB-09GR200-5.5D16	2.00	5.5	15.0	10.5	0.20	16.0
MB-09GR250-5.5D16	2.50	5.5	15.0	10.5	0.20	16.0
MB-09GR300-5.5D16	3.00	5.5	15.0	10.5	0.20	16.0
MB-09GR150-6.5D17	1.50	6.5	16.0	11.5	0.10	17.0
MB-09GR200-6.5D17	2.00	6.5	16.0	11.5	0.20	17.0
MB-09GR250-6.5D17	2.50	6.5	16.0	11.5	0.20	17.0
MB-09GR300-6.5D17	3.00	6.5	16.0	11.5	0.20	17.0

Insert
External Toolholder
Internal Toolholder
Threading
Parting, Grooving
Miniature Tool

MG SERIES

Modular Small Hole Cutter for Toolholders

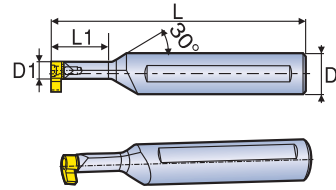

Fig.1

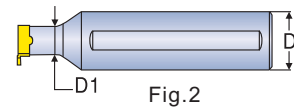
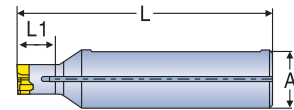

Fig.2

Order No.	D	D1	L1	L	A	Insert	Wrench	Screw	Fig.
MG-H12-18-05R	12	5	18	100	11.6	MB-05..	WC06	CSTB22	1
MG-H16-20-07R	16	7	20	120	15.0	MB-07..	WC10	CSTB30	2
MG-H16-30-09R	16	9	30	120	15.0	MB-09..	WC15	CSTB40	2

Standard Cutting Conditions

ISO	Workpiece material		Vc(m/min)	f(mm/min)
P	Non-Alloy steel	<0.25%C	40-180	0.30-0.50
		0.25%C- 0.55%C	40-170	0.30-0.50
		≥ 0.55%C	40-160	0.25-0.35
	Low Alloy Steel		40-190	0.25-0.45
	High Alloy Steel		40-115	0.18-0.30
M	Martensitic Stainless Steel		40-100	0.20-0.35
	Austenitic Stainless Steel		40-90	0.15-0.35
K	Grey Cast Iron		40-70	0.20-0.35
	Ductile Cast Iron		50-80	0.15-0.30
N	Cast Aluminum Alloy		100-300	0.50-1.00
	Aluminum Alloy		60-150	0.50-0.90
	Copper Alloy		100-150	0.50-0.90
S	Heat-resistance Alloy		10-45	0.10-0.20
	Titanium Alloy		40-60	0.10-0.20

Technical Information

Basic size step (mm)		Tolerance zone class of hole (μm)																																		
		>	\leq	B10	C9	C10	D8	D9	D10	E7	E8	E9	F6	F7	F8	G6	G7	H6	H7	H8	H9	H10	JS6	JS7	K6	K7	M6	M7	N6	N7	P6	P7	R7	S7	T7	U7
-	3	+180	+85	+100	+34	+45	+60	+24	+28	+39	+12	+16	+20	+8	+12	+6	+10	+14	+25	+40	± 3	± 5	0	0	-2	-2	-4	-4	-6	-6	-10	-14	-14	-18	-20	
		+140	+60	+60	+20	+20	+20	+14	+14	+14	+6	+6	+6	+2	+2	0	0	0	0	0	0	± 3	± 5	-6	-10	-8	-12	-10	-14	-12	-16	-20	-24	-	-28	-30
3	6	+188	+100	+118	+48	+60	+78	+32	+38	+50	+18	+22	+28	+12	+16	+8	+12	+18	+30	+48	± 4	± 6	+2	+3	-1	0	-5	-4	-9	-8	-11	-15	-	-19	-24	
		+140	+70	+70	+30	+30	+30	+20	+20	+20	+10	+10	+10	+4	+4	0	0	0	0	0	0	± 4	± 6	-6	-9	-9	-12	-13	-16	-17	-20	-23	-27	-	-31	-36
6	10	+208	+116	+138	+62	+76	+98	+40	+47	+61	+22	+28	+35	+14	+20	+9	+15	+22	+36	+58	± 4.5	± 7	+2	+5	-3	0	-7	-4	-12	-9	-13	-17	-	-22	-28	
		+150	+80	+80	+40	+40	+40	+25	+25	+25	+13	+13	+13	+5	+5	0	0	0	0	0	0	± 4.5	± 7	-7	-10	-12	-15	-16	-19	-21	-24	-28	-32	-	-37	-43
10	14	+220	+138	+165	+77	+93	+120	+50	+59	+75	+27	+34	+43	+17	+24	+11	+18	+27	+43	+70	± 5.5	± 9	+2	+6	-4	0	-9	-5	-15	-11	-16	-21	-	-26	-33	
		+150	+95	+95	+50	+50	+50	+32	+32	+32	+16	+16	+16	+6	+6	0	0	0	0	0	0	± 5.5	± 9	-9	-12	-15	-18	-20	-23	-26	-29	-34	-39	-	-44	-51
18	24	+244	+162	+194	+98	+117	+149	+61	+73	+92	+33	+41	+53	+20	+28	+13	+21	+33	+52	+84	± 6.5	± 10	+2	+6	-4	0	-11	-7	-18	-14	-20	-27	-	-33	-46	
		+160	+110	+110	+65	+65	+65	+40	+40	+40	+20	+20	+20	+7	+7	0	0	0	0	0	0	± 6.5	± 10	-11	-15	-17	-21	-24	-28	-31	-35	-41	-48	-54	-61	
24	30	+270	+182	+220		+119	+142	+180	+75	+89	+112	+41	+50	+64	+25	+34	+16	+25	+39	+62	+100	± 8	± 12	+3	+7	-4	0	-12	-8	-21	-17	-25	-34	-39	-45	-51
		+170	+120	+120		+119	+142	+180	+75	+89	+112	+41	+50	+64	+25	+34	+16	+25	+39	+62	+100	± 8	± 12	-13	-18	-20	-25	-28	-33	-37	-42	-50	-59	-64	-76	-
30	40	+280	+192	+230	+80	+80	+80	+50	+50	+50	+25	+25	+25	+9	+9	0	0	0	0	0	0	± 9.5	± 15	+4	+9	-5	0	-14	-9	-26	-21	-30	-42	-55	-76	
		+180	+130	+130		+119	+142	+180	+75	+89	+112	+41	+50	+64	+25	+34	+16	+25	+39	+62	+100	± 9.5	± 15	-15	-21	-24	-30	-33	-39	-45	-51	-60	-72	-85	-106	-
50	65	+310	+214	+260		+174	+220	+90	+106	+134	+49	+60	+76	+29	+40	+19	+30	+46	+74	+120	± 11	± 17	+4	+10	-6	0	-16	-10	-30	-24	-38	-58	-78	-111		
		+190	+140	+140	+146	+174	+220	+90	+106	+134	+49	+60	+76	+29	+40	+19	+30	+46	+74	+120	± 11	± 17	-15	-21	-24	-30	-33	-39	-45	-51	-62	-78	-94	-121	-	
80	100	+360	+257	+310	+174	+207	+260	+107	+126	+159	+58	+71	+90	+34	+47	+22	+35	+54	+87	+140	± 12.5	± 20	+4	+10	-6	0	-16	-10	-30	-24	-41	-66	-91	-131		
		+220	+170	+170	+145	+145	+145	+85	+85	+85	+43	+43	+43	+14	+14	0	0	0	0	0	0	± 12.5	± 20	-18	-25	-28	-35	-38	-45	-52	-59	-76	-101	-126		
120	140	+420	+300	+360		+208	+245	+305	+125	+148	+185	+68	+83	+106	+39	+54	+25	+40	+63	+100	+160	± 14.5	± 23	+4	+12	-8	0	-20	-12	-36	-28	-50	-85	-119		
		+260	+200	+200		+208	+245	+305	+125	+148	+185	+68	+83	+106	+39	+54	+25	+40	+63	+100	+160	± 14.5	± 23	-21	-28	-33	-40	-45	-52	-61	-68	-90	-125	-159	-	
140	160	+440	+310	+370	+208	+210	+210	+145	+145	+85	+85	+85	+43	+43	+43	+14	+14	0	0	0	0	± 14.5	± 23	+5	+13	-8	0	-22	-14	-41	-33	-63	-113			
		+280	+210	+210	+145	+145	+85	+85	+85	+43	+43	+43	+14	+14	0	0	0	0	0	0	0	± 14.5	± 23	-24	-33	-37	-46	-51	-60	-70	-79	-109	-159	-		
160	180	+470	+330	+390																		± 16	± 26	+7	+17	-10	0	-26	-16	-51	-41	-87	-144			
		+310	+230	+230																			± 16	± 26	-29	-40	-46	-57	-62	-73	-87	-98	-144	-		
180	200	+525	+355	+425																		± 18	± 28	+7	+17	-10	0	-26	-16	-51	-41	-87	-144			
		+340	+240	+240																			± 18	± 28	-29	-40	-46	-57	-62	-73	-87	-98	-144	-		
200	225	+565	+375	+445	+242	+285	+355	+146	+172	+215	+79	+96	+122	+44	+61	+29	+46	+72	+115	+185	± 14.5	± 23	+5	+13	-8	0	-22	-14	-41	-33	-63	-113				
		+380	+260	+260	+170	+170	+170	+100	+100	+100	+50	+50	+50	+15	+15	0	0	0	0	0	0	± 14.5	± 23	-24	-33	-37	-46	-51	-60	-70	-79	-109	-159	-		
225	250	+605	+395	+465																		± 16	± 26	+7	+17	-10	0	-26	-16	-51	-41	-87	-144			
		+420	+280	+280																			± 16	± 26	-29	-40	-46	-57	-62	-73	-87	-98	-144	-		
250	280	+690	+430	+510																		± 18	± 28	+7	+17	-10	0	-26	-16	-51	-41	-87	-144			
		+480	+300	+300	+271	+320	+400	+162	+191	+240	+88	+108	+137	+49	+69	+32	+52	+81	+130	+210	± 16	± 26	-27	-36	-41	-52	-57	-66	-79	-88	-130	-				
280	315	+750	+460	+540	+190	+190	+190	+110	+110	+110	+56	+56	+56	+17	+17	0	0	0	0	0	± 16	± 26	+7	+17	-10	0	-26	-16	-51	-41	-87	-144				
		+540	+330	+330																			± 16	± 26	-29	-40	-46	-57	-62	-73	-87	-98	-144	-		
315	355	+830	+500	+590																		± 18	± 28	+7	+17	-10	0	-26	-16	-51	-41	-87	-144			
		+600	+360	+360	+299	+350	+440	+182	+214	+265	+98	+119	+151	+54	+75	+36	+57	+89	+140	+230	± 18	± 28	-29	-40	-46	-57	-62	-73	-87	-98	-144	-				
355	400	+910	+540	+630	+210	+210	+210	+125	+125	+125	+62	+62	+62	+18	+18	0	0	0	0	0	± 20	± 31	+8	+18	-10	0	-27	-17	-55	-45	-103	-166				
		+680	+400	+400																			± 20	± 31	-29	-40	-46	-57	-62	-73	-87	-98	-144	-		
400	450	+1010	+595	+690																		± 20	± 31	+8	+18	-10	0	-27	-17	-55	-45	-103	-166			
		+760	+440	+440	+327	+385	+480	+198	+232	+290	+108	+131	+165	+60	+83	+40	+63	+97	+155	+250	± 20	± 31	-32	-45	-50	-63	-67	-80	-95	-108	-166	-				
450	500	+1090	+635	+730	+230	+230	+230	+135	+135	+135	+68	+68	+68	+20	+20	0	0	0	0	0	± 20	± 31	+8	+18	-10	0	-27	-17	-55	-45	-103	-166				
		+840	+480	+480																			± 20	± 31	-32	-45	-50	-63	-67	-80	-95	-108	-166	-		

In every step given in the table, the value on the upper side shows the upper deviation and the value on the lower side, the lower deviation.

Technical Information

Basic size step (mm)		Tolerance zone class of shaft (μm)																																
		>	\leq	b9	c9	d8	d9	e7	e8	e9	f6	f7	f8	g5	g6	h5	h6	h7	h8	h9	js5	js6	js7	k5	k6	m5	m6	n6	p6	r6	s6	t6	u6	x6
-	3	-140	-60	-20	-20	-14	-14	-14	-6	-6	-6	-2	-2	0	0	0	0	0	0	0	± 2	± 3	± 5	+4	+6	+6	+8	+10	+12	+16	+20	-	+24	+26
		-165	-85	-34	-45	-24	-28	-39	-12	-16	-20	-6	-8	-4	-6	-10	-14	-25						0	0	+2	+2	+4	+6	+10	+14		+18	+20
3	6	-140	-70	-30	-30	-20	-20	-20	-10	-10	-10	-4	-4	0	0	0	0	0	0	0	± 2.5	± 4	± 6	+6	+9	+9	+12	+16	+20	+23	+27	-	+31	+36
		-170	-100	-48	-60	-32	-38	-50	-18	-22	-28	-9	-12	-5	-8	-12	-18	-30						+1	+1	+4	+4	+8	+12	+15	+19		+23	+28
6	10	-150	-80	-40	-40	-25	-25	-25	-13	-13	-13	-5	-5	0	0	0	0	0	0	0	± 3	± 4.5	± 7	+7	+10	+12	+15	+19	+24	+28	+32	-	+37	+43
		-186	-116	-62	-76	-40	-47	-61	-22	-28	-35	-11	-14	-6	-9	-15	-22	-36						+1	+1	+6	+6	+10	+15	+19	+23		+28	+34
10	14	-150	-95	-50	-50	-32	-32	-32	-16	-16	-16	-6	-6	0	0	0	0	0	0	0	± 4	± 5.5	± 9	+9	+12	+15	+18	+23	+29	+34	+39	-	+44	+51
		-193	-138	-77	-93	-50	-59	-75	-27	-34	-43	-14	-17	-8	-11	-18	-27	-43						+1	+1	+7	+7	+12	+18	+23	+28		+33	+40
18	24	-160	-110	-65	-65	-40	-40	-40	-20	-20	-20	-7	-7	0	0	0	0	0	0	0	± 4.5	± 6.5	± 10	+11	+15	+17	+21	+28	+35	+41	+48	-	+54	+67
		-212	-162	-98	-117	-61	-73	-92	-33	-41	-53	-16	-20	-9	-13	-21	-33	-52						+2	+2	+8	+8	+15	+22	+23	+35		+41	+54
30	40	-170	-120	-80	-80	-50	-50	-50	-25	-25	-25	-9	-9	0	0	0	0	0	0	0	± 5.5	± 8	± 12	+13	+18	+20	+25	+33	+42	+50	+59	+64	+76	
		-232	-182	-119	-142	-75	-89	-112	-41	-50	-64	-20	-25	-11	-16	-25	-39	-62						+2	+2	+9	+9	+17	+26	+34	+43	+48	+60	+70
50	65	-190	-140	-100	-100	-60	-60	-60	-30	-30	-30	-10	-10	0	0	0	0	0	0	0	± 6.5	± 9.5	± 15	+15	+21	+24	+30	+39	+51	+60	+72	+85	+106	
		-264	-214	-146	-174	-90	-106	-134	-49	-60	-76	-23	-29	-13	-19	-30	-46	-74						+2	+2	+11	+11	+20	+32	+43	+59	+66	+87	+102
80	100	-220	-170	-120	-120	-72	-72	-72	-36	-36	-36	-12	-12	0	0	0	0	0	0	0	± 7.5	± 11	± 17	+18	+25	+28	+35	+45	+59	+73	+93	+113	+146	
		-307	-257	-174	-207	-107	-126	-159	-58	-71	-90	-27	-34	-15	-22	-35	-54	-87						+3	+3	+13	+13	+23	+37	+43	+54	+61	+79	+104
120	140	-260	-200	-145	-145	-85	-85	-85	-43	-43	-43	-14	-14	0	0	0	0	0	0	0	± 9	± 12.5	± 20	+21	+28	+33	+40	+52	+68	+88	+117	+147		
		-360	-300	-208	-245	-125	-148	-185	-68	-83	-106	-32	-39	-18	-25	-40	-63	-100						+3	+3	+15	+15	+27	+43	+65	+93	+125	+159	+199
160	180	-310	-230	-245	-245	-125	-148	-185	-68	-83	-106	-32	-39	-18	-25	-40	-63	-100						+3	+3	+15	+15	+27	+43	+65	+93	+125	+159	+199
		-410	-330	-245	-245	-125	-148	-185	-68	-83	-106	-32	-39	-18	-25	-40	-63	-100						+3	+3	+15	+15	+27	+43	+65	+93	+125	+159	+199
180	200	-340	-240	-170	-170	-100	-100	-100	-50	-50	-50	-15	-15	0	0	0	0	0	0	0	± 10	± 14.5	± 23	+24	+33	+37	+46	+60	+79	+106	+151	+199	+256	
		-455	-355	-242	-285	-146	-172	-215	-79	-96	-122	-35	-44	-20	-29	-46	-72	-115						+4	+4	+17	+17	+31	+50	+71	+99	+134	+179	+236
250	280	-480	-300	-190	-190	-110	-110	-110	-56	-56	-56	-17	-17	0	0	0	0	0	0	0	± 11.5	± 16	± 26	+27	+36	+43	+52	+66	+88	+126	+172	+229	+300	
		-610	-430	-271	-320	-162	-191	-240	-88	-108	-137	-40	-49	-23	-32	-52	-81	-130						+4	+4	+20	+20	+34	+56	+81	+113	+153	+204	+267
315	355	-600	-360	-210	-210	-125	-125	-125	-62	-62	-62	-18	-18	0	0	0	0	0	0	0	± 12.5	± 18	± 28	+29	+40	+46	+57	+73	+98	+144	+198	+264	+345	
		-820	-540	-299	-350	-182	-214	-265	-98	-119	-151	-43	-54	-25	-36	-57	-89	-140						+4	+4	+21	+21	+37	+62	+91	+126	+171	+228	+303
400	450	-760	-440	-230	-230	-135	-135	-135	-68	-68	-68	-20	-20	0	0	0	0	0	0	0	± 13.5	± 20	± 31	+32	+45	+50	+63	+80	+108	+166	+231	+309	+402	
		-995	-635	-327	-385	-198	-232	-290	-108	-131	-165	-47	-60	-27	-40	-63	-97	-155						+5	+5	+23	+23	+40	+68	+102	+142	+192	+255	+336

Technical Information

Approximate Conversion Value for Brinel Hardness.

HB		HV	Rockwell*3				HS	Approx. tensile strength (MPa) *2	HB		HV	Rockwell*3				HS	Approx. tensile strength (MPa) *2
Brinell, 10mm ball, Load 3000kg			HRA	HRB	HRC	HRD			Brinell, 10mm ball, Load 3000kg			HRA	HRB	HRC	HRD		
Standard ball	Tungsten carbide ball	Vickers					A Scale, Load 60kg, Brale Diamond	B Scale, Load 100kg, Diameter 1/16 in. Steel ball	C Scale, Load 150kg, Brale Diamond	D Scale, Load 100kg, Brale Diamond	Shore					Standard ball	Tungsten carbide ball
-	-	1865	92.0	-	80	-	-	269	269	284	64.1	(104.0)	27.6	45.9	40	91	
-	-	1787	91.5	-	79	-	-	262	262	276	63.6	(103.0)	26.6	45.0	39	89	
-	-	1710	91.0	-	78	-	-	255	255	269	63.0	(102.0)	25.4	44.2	38	86	
-	-	1633	90.5	-	77	-	-	248	248	261	62.5	(101.0)	24.2	43.2	37	84	
-	-	1556	90.0	-	76	-	-	241	241	253	61.8	100.0	22.8	42.0	36	82	
-	-	1478	89.5	-	75	-	-	235	235	247	61.4	99.0	21.7	41.4	35	80	
-	-	1400	89.0	-	74	-	-	229	229	241	60.8	98.2	20.5	40.5	34	78	
-	-	1323	88.5	-	73	-	-	223	223	234	-	97.3	(18.8)	-	-	-	
-	-	1245	88.0	-	72	-	-	217	217	228	-	96.4	(17.5)	-	33	74	
-	-	1160	87.0	-	71	-	-	212	212	222	-	95.5	(16.0)	-	-	72	
-	-	1076	86.5	-	70	-	-	207	207	218	-	94.6	(15.2)	-	32	70	
-	-	1004	86.0	-	69	-	-	201	201	212	-	93.8	(13.8)	-	31	69	
-	-	940	85.6	-	68.0	76.9	97	197	197	207	-	92.8	(12.7)	-	30	67	
-	-	920	85.3	-	67.5	76.5	96	192	192	202	-	91.9	(11.5)	-	29	65	
-	-	900	85.0	-	67.0	76.1	95	187	187	196	-	90.7	(10.0)	-	-	63	
-	767	880	84.7	-	66.4	75.7	93	-	-	-	-	-	-	-	-	-	
-	757	860	84.4	-	65.9	75.3	92	-	-	-	-	-	-	-	-	-	
-	745	840	84.1	-	65.3	74.8	91	183	183	192	-	90.0	(9.0)	-	28	63	
-	733	820	83.8	-	64.7	74.3	90	179	179	188	-	89.0	(8.0)	-	27	61	
-	722	800	83.4	-	64.0	73.8	88	174	174	182	-	87.8	(6.4)	-	-	60	
-	712	-	-	-	-	-	-	170	170	178	-	86.8	(5.4)	-	26	58	
-	710	780	83.0	-	63.3	73.3	87	167	167	175	-	86.0	(4.4)	-	-	57	
-	698	760	82.6	-	62.5	72.6	86	163	163	171	-	85.0	(3.3)	-	25	56	
-	684	740	82.2	-	61.8	72.1	-	156	156	163	-	82.9	(0.9)	-	-	53	
-	682	737	82.2	-	61.7	72.0	84	149	149	156	-	80.8	-	-	23	51	
-	670	720	81.8	-	61.0	71.5	83	143	143	150	-	78.7	-	-	22	50	
-	656	700	81.3	-	60.1	70.8	-	137	137	143	-	76.4	-	-	21	47	
-	653	697	81.2	-	60.0	70.7	81	131	131	137	-	74.0	-	-	-	46	
-	647	690	81.1	-	59.7	70.5	-	126	126	132	-	72.0	-	-	20	44	
-	638	680	80.8	-	59.2	70.1	80	121	121	127	-	69.8	-	-	19	42	
-	630	670	80.6	-	58.8	69.8	-	116	116	122	-	67.6	-	-	18	41	
-	627	667	80.5	-	58.7	69.7	79	111	111	117	-	65.7	-	-	17	39	
-	601	640	79.8	-	57.3	68.7	77	-	-	-	-	-	-	-	-	-	
-	578	615	79.1	-	56.0	67.7	75	-	-	-	-	-	-	-	-	-	
-	555	591	78.4	-	54.7	66.7	73	210	-	-	-	-	-	-	-	-	
-	534	569	77.8	-	53.5	65.8	71	202	-	-	-	-	-	-	-	-	
-	514	547	76.9	-	52.1	64.7	70	193	-	-	-	-	-	-	-	-	
-	495	528	76.3	-	51.0	63.8	68	186	-	-	-	-	-	-	-	-	
-	477	508	75.6	-	49.6	62.7	66	177	-	-	-	-	-	-	-	-	
-	461	491	74.9	-	48.5	61.7	65	170	-	-	-	-	-	-	-	-	
-	444	472	74.2	-	47.1	60.8	63	162	-	-	-	-	-	-	-	-	
429	429	455	73.4	-	45.7	59.7	61	154	-	-	-	-	-	-	-	-	
415	415	440	72.8	-	44.5	58.8	59	149	-	-	-	-	-	-	-	-	
401	401	425	72.0	-	43.1	57.8	58	142	-	-	-	-	-	-	-	-	
388	388	410	71.4	-	41.8	56.8	56	136	-	-	-	-	-	-	-	-	
375	375	396	70.6	-	40.4	55.7	54	129	-	-	-	-	-	-	-	-	
363	363	383	70.0	-	39.1	54.6	52	124	-	-	-	-	-	-	-	-	
352	352	372	69.3	(110.0)	37.9	53.8	51	120	-	-	-	-	-	-	-	-	
341	341	360	68.7	(109.0)	36.6	52.8	50	115	-	-	-	-	-	-	-	-	
331	331	350	68.1	(108.5)	36.6	51.9	48	112	-	-	-	-	-	-	-	-	
321	321	339	67.5	(108.0)	34.3	51.0	47	108	-	-	-	-	-	-	-	-	
311	311	328	66.9	(107.5)	33.1	50.0	46	105	-	-	-	-	-	-	-	-	
302	302	319	66.3	(107.0)	32.1	49.3	45	103	-	-	-	-	-	-	-	-	
293	293	309	65.7	(106.0)	30.9	48.3	43	99	-	-	-	-	-	-	-	-	
285	285	301	65.3	(105.5)	29.9	47.6	-	97	-	-	-	-	-	-	-	-	
277	277	292	64.6	(104.5)	28.8	46.7	41	94	-	-	-	-	-	-	-	-	